



RISORSE DIDATTICHE.



[ResearchGate Project](#) By ... 0000-0001-5086-7401 & [Inkd.in/erZ48tm](https://www.linkedin.com/in/erZ48tm)



.....



.....

Origami a 360° ... e oltre

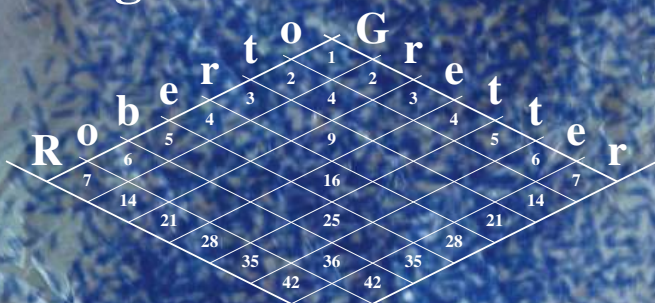

QQM
49



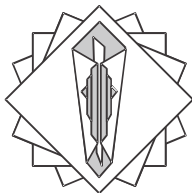

QM 49

CENTRO DIFFUSIONE ORIGAMI

Casella postale 28
27011 Belgioioso (PV)
e-mail: info@origami-cdo.it
www.origami-cdo.it

QUADERNO DI QUADRATO MAGICO N° 49

Supplemento di **QUADRATO MAGICO N° 104**
Direttore Responsabile: Roberto Morassi
Modelli e Diagrammi: Roberto Gretter

Redazione: Oscar Orlandi
Copertina: Roberto Gretter
Autorizzazione del Tribunale di Firenze
n° 2835 del 21/03/1980
© C.D.O. 2012

Origami a 360° ... e oltre

dedico questo lavoro ai miei familiari,
alle persone che mi sono vicine,
agli amici di piega...
ma soprattutto ai miei genitori,
Gabriella e Mario,
che mi hanno insegnato
le poche cose importanti che so.



Robert Guter

Origami a 360° ... e oltre

Mi piace esplorare, provare, sperimentare, cercare nuove vie. Mi piace la carta perché è umile, tiene occupate le mani e la mente, permette la magia della trasformazione. Non vorrei che leggendo il titolo si pensasse che ho la pretesa di sapere tutto, anzi. Mi ritengo in continua esplorazione, e mi piace pensare di condividere con altri le mie piccole scoperte, che spesso altri prima di me hanno trovato. Non mi ritengo un esperto, ma piuttosto un appassionato pasticcione che si diverte a piegare in tutte le direzioni, qualcuno che inizia cento cose senza riuscire a finirne nes

D'altra parte la miglior definizione di esperto che ho trovato - fa parte delle leggi di Murphy - recita pressappoco così: *l'esperto è quella persona che, evitando accuratamente tutti i piccoli errori, punta dritto alla catastrofe*. Mi piacciono tutti i tipi di origami: figurativi e geometrici, facili e difficili, modulari e non, di movimento, impegnativi e rilassanti, inventati da me o da altri, piegati da solo o in compagnia. E nonostante faccia origami ormai da una quindicina di anni, riesco ancora a rimanere stupito vedendo come un foglio possa trasformarsi in qualcosa di impreveduto o assolutamente meraviglioso, a come si riesca a strappare un sorriso - poche cose sono più belle - alla persona che si ha di fronte quando si regala o si insegna un modello, al momento in cui "vedi" qualcosa: una insospettata geometria che ti si rivela improvvisamente, una chiusura che ti ha impegnato a lungo e finalmente riesce.

QQM 49. Ho iniziato a lavorarci a 49 anni, il mio nome e il mio cognome sono composti da 7 lettere, *7x7* fa 49, da sempre considero il 7 il mio numero fortunato. Non potevo lasciarmelo sfuggire, come non potevo continuare a dire di no a Luigi Leonardi, che ha la responsabilità di avermi spinto a realizzare questo lavoro. Mi sono reso conto che in questi ultimi anni l'impegno nel direttivo del CDO mi ha lasciato poco spazio per diagrammare i miei lavori, così ne ho approfittato per fare ordine tra alcuni dei miei progetti e per rivisitare alcuni dei miei modelli preferiti, che ripropongo qui.

Un grazie a Stefania Serre per un controllo dell'ultimo minuto di gran parte dei diagrammi. Per quanto riguarda gli errori rimasti, naturalmente ne detengo responsabilità e copyright.

In ultimo, non posso terminare questa presentazione senza ricordare le seguenti bellissime ed immortali parole:



al Sole,
che con i suoi Raggi
ci scalda il Cuore
e suscita Amore
senza il quale Nulla ha ragione di
essere

P. Calzelunghe

Indice dei modelli

- 4 Tassellazioni radiali
- 6 Mosses base per tassellazioni radiali
- 12 Tassellazione radiale a simmetria 8
- 16 Tassellazione a rosone a simmetria 12
- 23 Pieghe curve
- 26 Vaso di Ginevra
- 28 Botte
- 30 Vaso #15 – crease pattern
- 31 Vaso #4 – crease pattern
- 32 Vaso #2 – crease pattern
- 33 Pieghe stropicciate
- 35 Albero per novembre – crease pattern
- 36 Albero per novembre
- 42 Albero fraterno 4x – crease pattern
- 43 Albero fraterno 7x – crease pattern
- 44 Albero fraterno 7x – iterazione
- 48 Modelli qua e là
- 49 Angelo
- 50 Segnaposto cuore
- 51 Pecora
- 54 Cagnolino
- 57 Copri copertina
- 58 Nike – scatola con chiusura
- 62 Scatola Corocoina
- 64 Scatola con 8 cuori
- 66 Segnalibro quadrifoglio
- 68 DNA bicolore – variazione del DNA di Thoki Yenn
- 70 Papavero
- 72 Nontiscordarime
- 73 Fiore... con la stella
- 77 Fiore d'aprile
- 80 Carozzina
- 85 Torri modulari
- 87 HLT – crease pattern progressivo
- 88 CDO – crease pattern progressivo
- 89 Armatura da legionario
- 92 Albero di Natale
- 95 Racchetta da tennis – crease pattern
- 96 Triplano Fokker Dr. 1 – crease pattern
- 4 Tassellazioni radiali
- 6 Mosses base per tassellazioni radiali
- 12 Tassellazione radiale a simmetria 8
- 16 Tassellazione a rosone a simmetria 12
- 23 Pieghe curve
- 26 Vaso di Ginevra
- 28 Botte
- 30 Vaso #15 – crease pattern
- 31 Vaso #4 – crease pattern
- 32 Vaso #2 – crease pattern
- 33 Pieghe stropicciate
- 35 Albero per novembre – crease pattern
- 36 Albero per novembre
- 42 Albero fraterno 4x – crease pattern
- 43 Albero fraterno 7x – crease pattern
- 44 Albero fraterno 7x – iterazione
- 48 Modelli qua e là
- 49 Angelo
- 50 Segnaposto cuore
- 51 Pecora
- 54 Cagnolino
- 57 Copri copertina
- 58 Nike – scatola con chiusura
- 62 Scatola Corocoina
- 64 Scatola con 8 cuori
- 66 Segnalibro quadrifoglio
- 68 DNA bicolore – variazione del DNA di Thoki Yenn
- 70 Papavero
- 72 Nontiscordarime
- 73 Fiore... con la stella
- 77 Fiore d'aprile
- 80 Carozzina
- 85 Torri modulari
- 87 HLT – crease pattern progressivo
- 88 CDO – crease pattern progressivo
- 89 Armatura da legionario
- 92 Albero di Natale
- 95 Racchetta da tennis – crease pattern
- 96 Triplano Fokker Dr. 1 – crease pattern

Tassellazioni radiali – Radial tessellations

Questo capitolo è ispirato sia da oggetti che si trovano in natura, come ad esempio una pigna o il centro di un girasole, dove i semi sono disposti a spirale, sia da artefatti umani, come i rosari delle chiese. La figura, composta da quadrati disposti opportunamente, cerca di rendere l'idea. L'ispirazione per questo tipo di lavori viene principalmente da Chris Palmer.

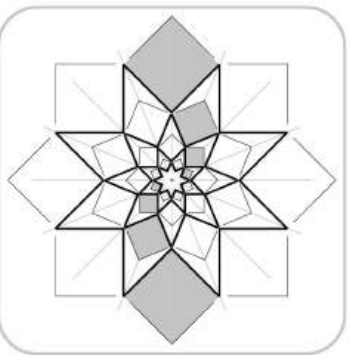

Le tassellazioni radiali si differenziano dalle tassellazioni "classiche" essenzialmente per due motivi. Il primo è strutturale: nelle tassellazioni classiche i tasselli sono tutti uguali, mentre in quelle radiali mano a mano che ci si allontana dal centro i tasselli, pur rimanendo uguali come forma, aumentano di dimensione. Il secondo è pratico: nelle tassellazioni classiche è possibile piegare una griglia in maniera estremamente semplice, dividendo il foglio - tipicamente quadrato o esagonale - in ognuna delle direzioni principali a metà, poi ancora a metà, poi ancora a metà... ottenendo griglie estremamente precise che contengono tutti i punti di riferimento necessari a chiudere il modello. Nelle tassellazioni radiali, invece, non ci sono griglie: ogni riferimento ottenuto serve come punto di partenza per le pieghe successive, quindi gli errori si propagano facilmente. Talvolta i punti di riferimento sono difficili da ottenere, ad esempio quando è necessario fare delle parallele a pieghe esistenti. Come conseguenza, per piegare i prossimi modelli occorre essere estremamente precisi.

This chapter is inspired both by objects found in nature, as for example a pine cone or the center of a sunflower, where the seeds are arranged in form of spirals, and by human artifacts, such as rose windows of churches. The figure, which consists of squares properly arranged, tries to get the idea. The inspiration for this type of work comes mainly from Chris Palmer.

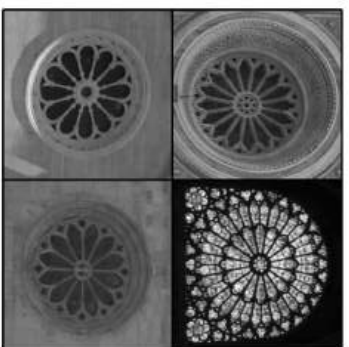

Radial tessellations differ from classic ones for two main reasons. The first is structural: the pieces in the classical tessellations are all the same, while in the radial ones, while maintaining the same form, they increase in size as we go away from the center. The second reason is practical: in classical tessellations it is possible to precrease a grid in an extremely simple way, by dividing the sheet - typically square or hexagonal - in each of main directions in half, then again in half, then again on half ... obtaining highly precise grids that contain all the reference points necessary to close the model. In radial tessellations, instead, this is not possible: each single reference point is a starting point for subsequent folds, so errors propagate easily. Sometimes the reference points are difficult to obtain, for example you will have to make a crease parallel to an existing one. As a consequence, to fold the next models you should be extremely precise.

La struttura di questi modelli non può prescindere da alcune caratteristiche comuni: deve esserci un centro, che per forza di cose deve essere un twist o un suo parente che permette di "guadagnare carta" in tutte le direzioni. La carta così ottenuta si allontana dal centro in maniera radiale e per evitare di essere noiosa dovrà dividersi a formare rami che si incrociano, riunendosi e separandosi in varie maniere. Le molte pieghe preparatorie indeboliscono la carta che potrebbe strapparsi: per questo conviene prepiegare tutto a foglio aperto e solo alla fine collasare il modello. Chiudere e riaprire le varie parti peggiora il risultato finale. Prima di piegare i modelli veri e propri conviene esercitarsi su alcune mosse base ed assicurarsi di aver capito i vari meccanismi:

- **centro:** le simmetrie qui proposte sono a base 8 o 12, il che porta da un lato ad affaticare la carta soprattutto nel centro, dove si concentrano molte pieghe, dall'altro a realizzare twist non banali. Da ogni centro partono 8 o 12 *strade*,
- **biforcazione:** quando una *strada* arriva ad un bivio, dando origine a due nuove *strade*,
- **incrocio:** quando due *strade* si incontrano, dando origine ad altre due nuove *strade* che possono avere direzioni diverse;
- **riunione:** quando due *strade* si incontrano e confluiscono in una sola.

Notare che ogni mossa base porta ad un crease pattern che può essere sia generalizzato (ottenendo figure simili che differiscono solo per alcuni degli angoli utilizzati) che risolto in maniere diverse, permettendo di ottenere numerose variazioni ai modelli proposti. Infine, vorrei dire che la bellezza di questi modelli sta nel collassarli, osservando via via le diverse figure geometriche che si formano.

The structure of these models shares some common features: there must be a center, basically a twist or something similar, which allows to gain paper in all directions. The earned paper moves away from the center in a radial way and to avoid to be boring has to divide to form branches that will cross, merge and split again in various ways. Many preparatory folds weaken the paper which may tear: so it is better to first precrease everything and collapse only at the end. Close and reopen various parts worsens the final result. Before folding real models it is better to practice with some basic moves and make sure to understand the various mechanisms:

- **center:** the symmetries proposed here are based on 8 or 12 sides, which tires the paper especially in the center, where many folds meet. Also closing such twists is not trivial. From the center depart either 8 or 12 roads;
- **split:** when a road comes to a fork, giving rise to two new roads;
- **cross:** when two roads meet, giving rise to two new roads that may have different directions;
- **merge:** where two roads meet and become just one.

Note that each basic move leads to a crease pattern that can be generalized (getting similar figures that differ only for some of the angles used) and resolved in different ways, allowing to obtain numerous changes to the proposed models. Finally, I would say that the beauty of these models is in the collapsing phase, when different geometric figures form.

Mosse base per tassellazioni radiali
Basic moves for radial tessellations

RG, febbraio 2011
difficoltà ①②③④⑤

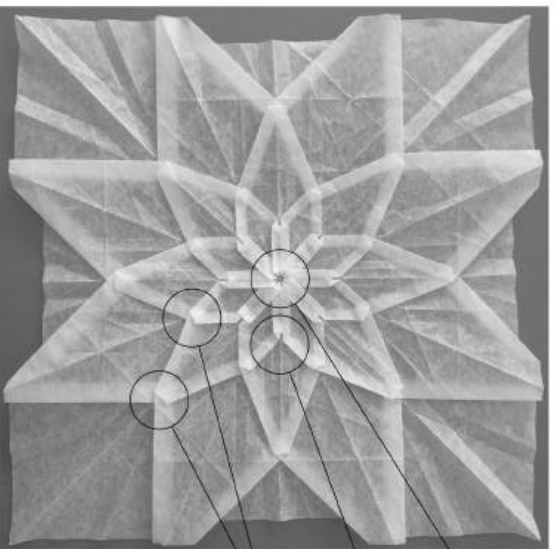

centro
center

biforcazione a 90°
90° split

incrocio a 90°
90° cross

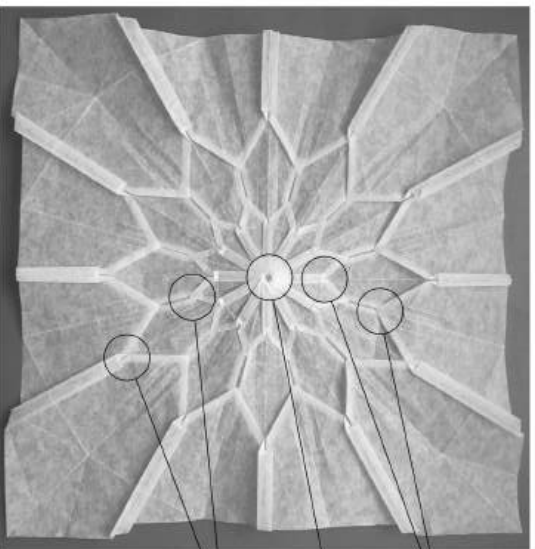

biforcazione a 90°
90° split

centro
center

riunione
merge

Tassellazione radiale a simmetria 8 – centro
Radial tessellation with symmetry 8 – center

RG, febbraio 2011
 difficoltà 1 2 3 4 5

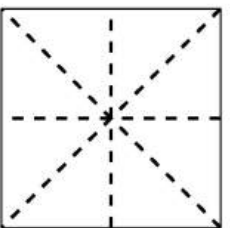

1 colore sotto, piega e riapri
color down, precrease

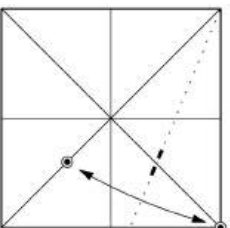

2

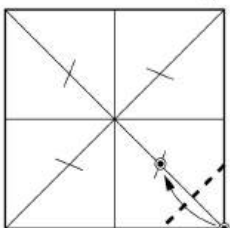

3

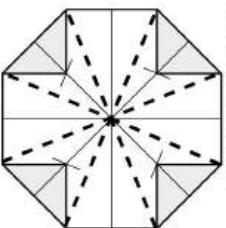

4 ottagono regolare, piega e riapri
regular octagon, precrease

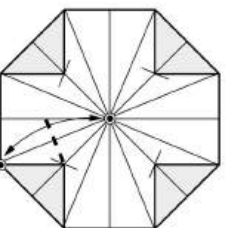

5

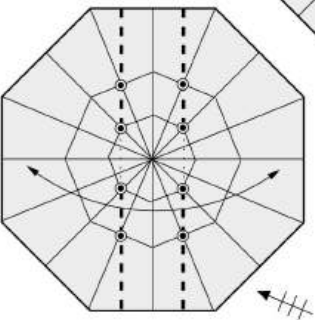

6

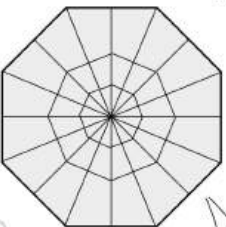

7

8

attento ai punti di riferimento
 allinea sulla piega verticale
*mind the reference points
 align on the vertical crease*

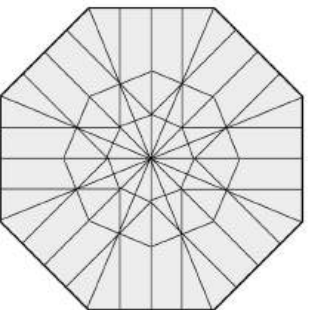

9

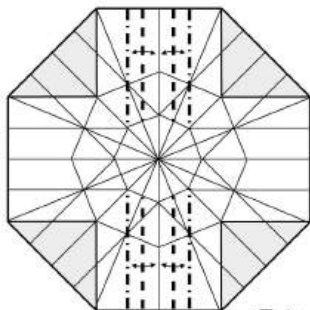

10 piega e riapri
precrease



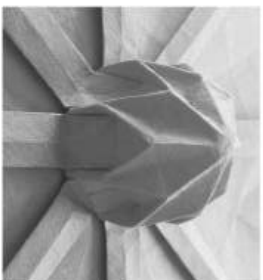
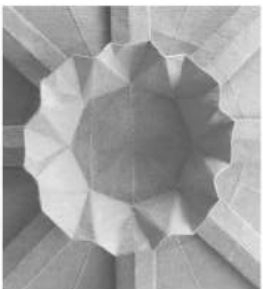

alcuni esempi di centro
some center examples

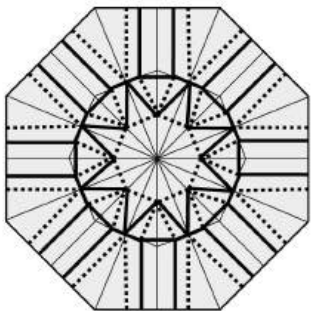

monte
mountain
valle
valley

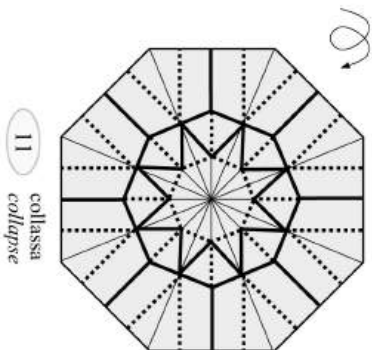

11
collassa
collapse

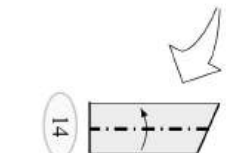

14

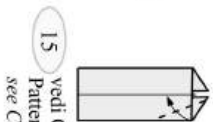

15

vedi Crease
Pattern sotto
see CP below

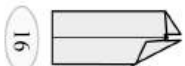

16

14-16

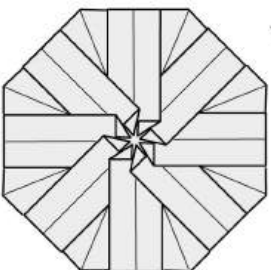

17
centro finito
center finished

14-16

13

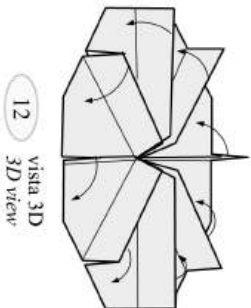
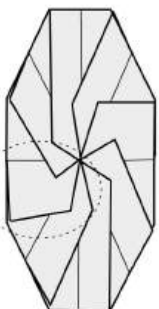

12
vista 3D
3D view



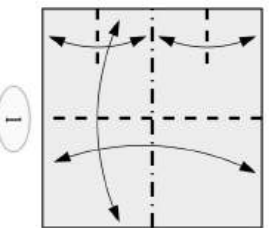

1

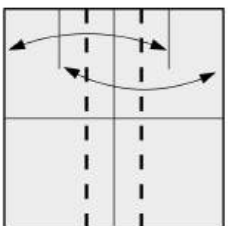

2

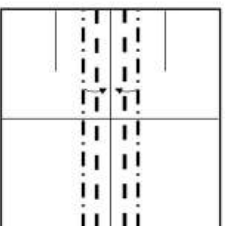

3

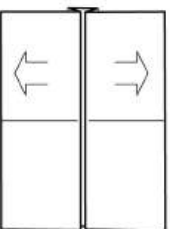

4

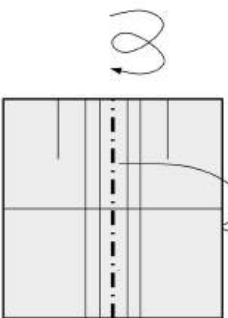

5



6

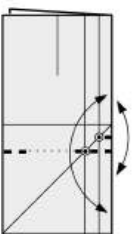

7
 pieghe verticali
vertical creases

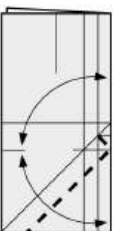

8
 pieghe a 45°
45° creases

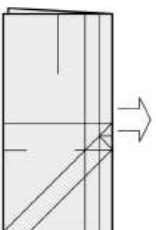

9

monte — mountain
 valle valley

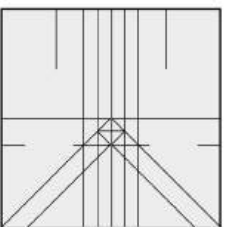

10

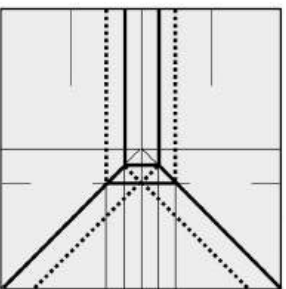

11

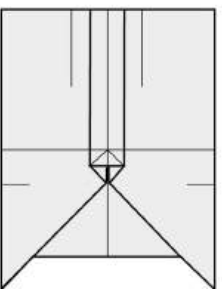

12
 biforcazione a 90° finita
90° split finished



Tassellazione radiale: incrocio a 90°
Radial tessellation: 90° cross

RG, febbraio 2011
 difficoltà 1 2 3 4 5

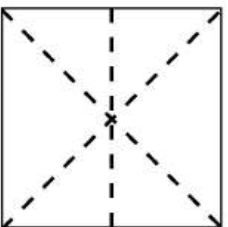

1

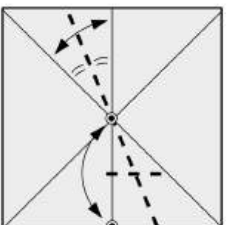

2
 bisettrice
bisect

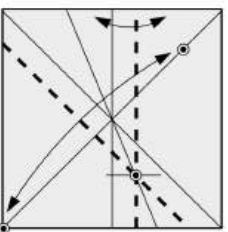

3
 pieghe parallele
parallel creases

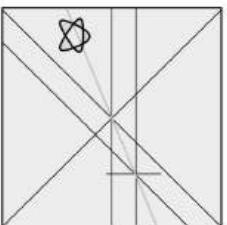

4
 in grigio la piega principale:
 fai un segno dove indicato
*the main crease is in gray;
 draw a sign where indicated*

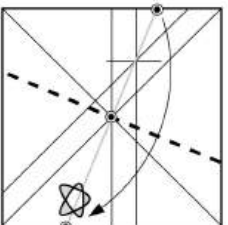

5
 perpendicolare alla
 piega principale
*perpendicular
 to the main crease*

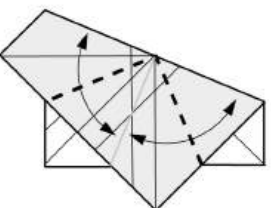

6
 piega e riapri
precrease

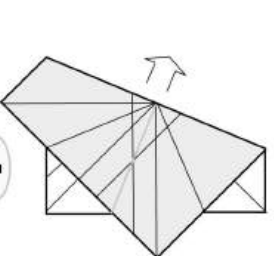

7

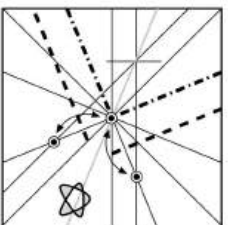

8
 pieghe parallele
parallel creases

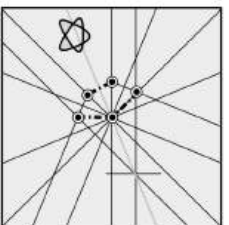

9

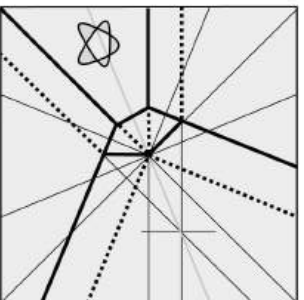

10
 collassa
collapse

monte
mountain
 valle
valley

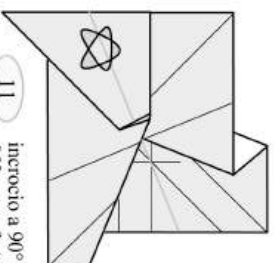

11
 incrocio a 90° finito
90° cross finished



Tassellazione radiale: riunione
Radial tessellation: merge

RG, febbraio 2012
 difficoltà 1 2 3 4 5

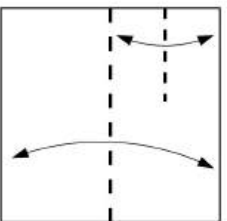

1

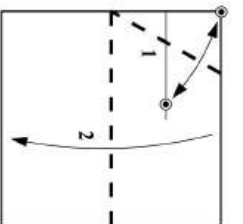

2

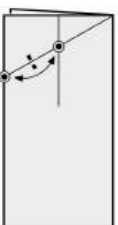

3

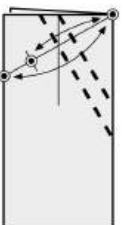

4



5
 perpendicolare
 perpendicular

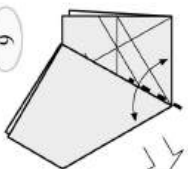

6

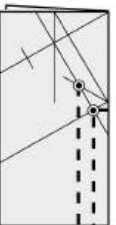

7
 pieghe orizzontali e verticali
 horizontal and vertical creases

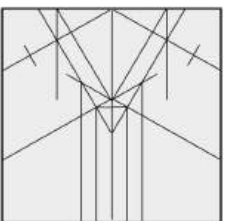

8

monte — mountain

valle valley

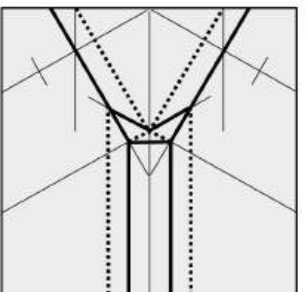

9
 collassa
 collapse

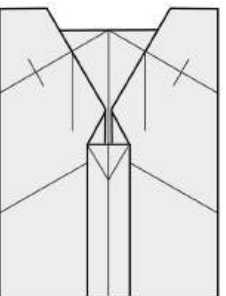

10
 riunione finita
 merge finished

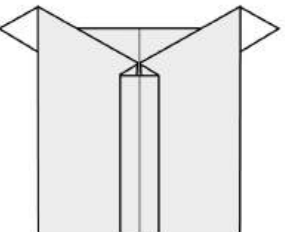
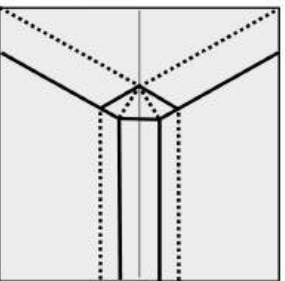

partendo da angolazioni diverse

starting from different angles



Tassellazione radiale a simmetria 8

RG, febbraio 2011
difficoltà 1 2 3 4 5

ispirato da lavori di Chris Palmer.

grazie ad Alessandro Beber per il suo prezioso aiuto

inspired by works of Chris Palmer,

many thanks to Alessandro Beber for his precious help

usa un quadrato di almeno 30 cm
use a square at least 12 inches (30 cm)

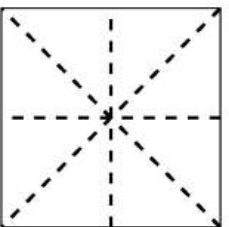

1 colore sotto, piega e riapri
color down, precrease

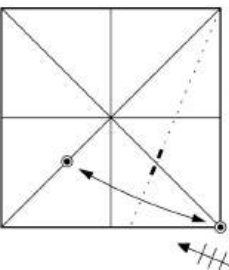

2

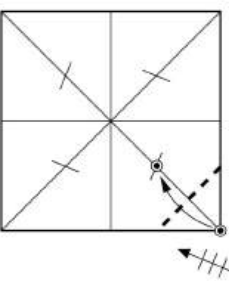

3 ottagono regolare
regular octagon

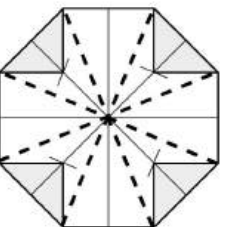

4 piega e riapri precrease

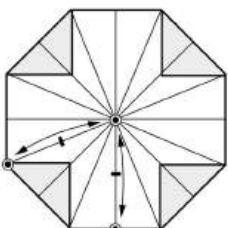

5

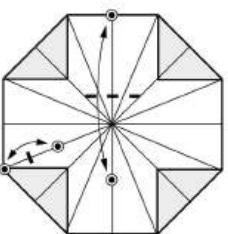

6

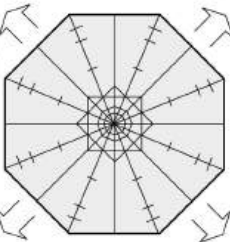
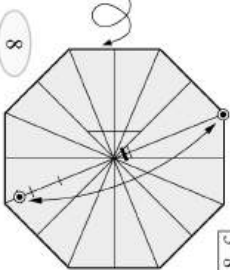
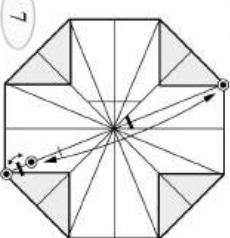

7

8

9

piega solo dove indicato
crease only where indicated

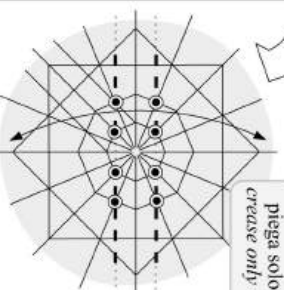

10 allinea sulla piega verticale
align on the vertical crease

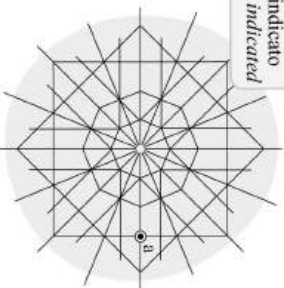

11 imposta le pieghe a monte e valle
reverse the creases where needed

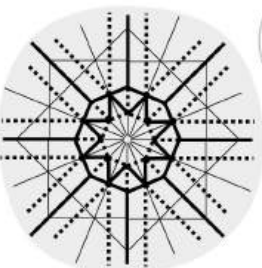

monte — mountain
valle valley



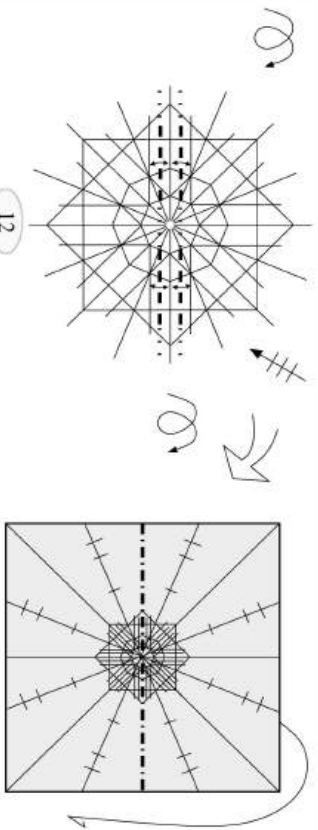

12

13

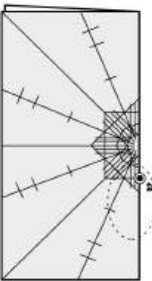

14
identifica il punto "a" del passo 11
identify point "a" of step 11

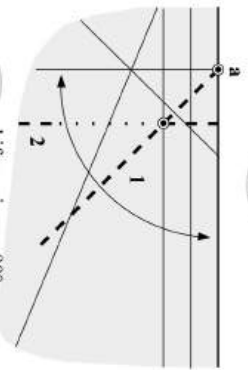

15
biforcazione a 90°
90° split

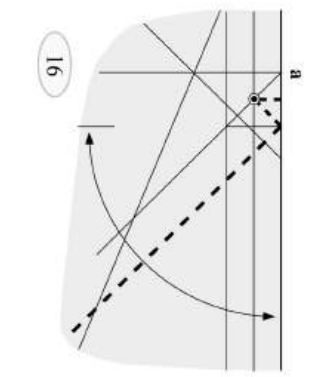

16

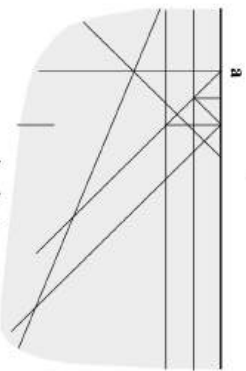

17
riapri tutto
reopen everything

monte ——— mountain
valle valley

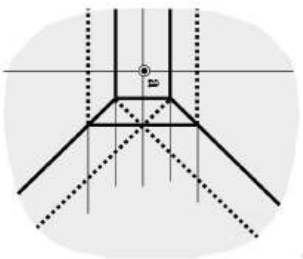

18
imposta le pieghe a monte e valle
reverse the creases where needed

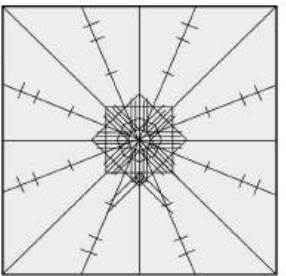

19

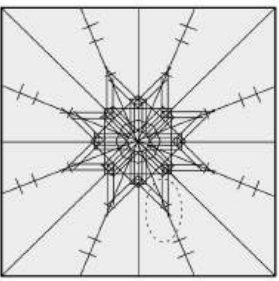

20



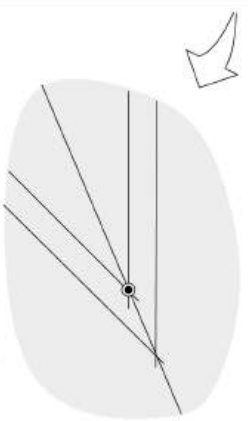

21
incrocio a 90°
90° cross

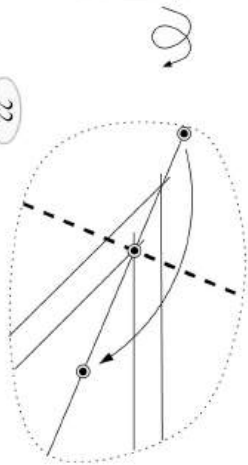

22

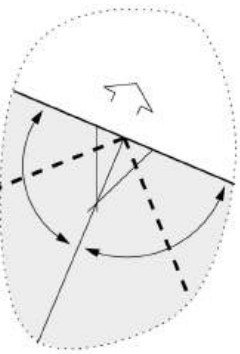

23

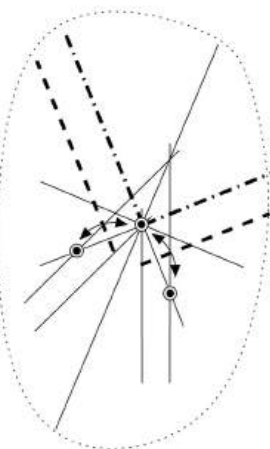

24
pieghe parallele
parallel creases

monte — mountain
valle valley

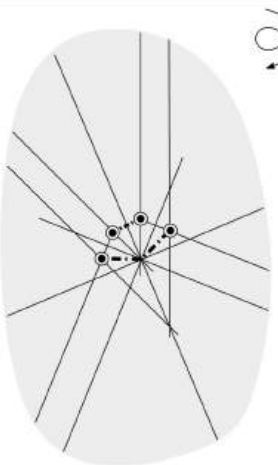

25

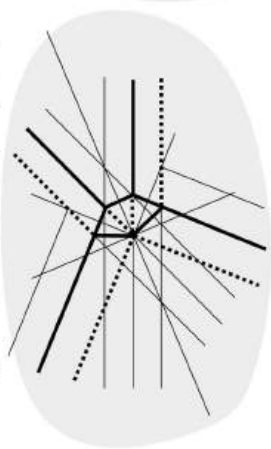

26
imposta le pieghe a monte e valle
reverse the creases where needed



22-26

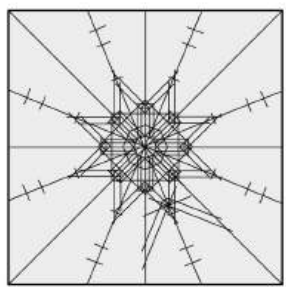

27

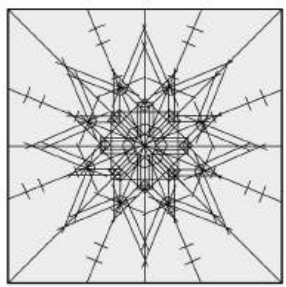

28

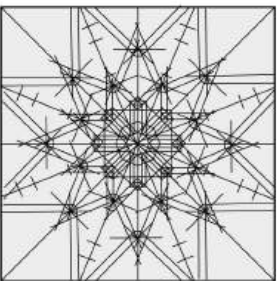

22-26



29 ripeti i passi 22/26 su ogni nuovo incrocio, fino alla fine della carta
repeat steps 22/26 on every new cross, until the end of the paper

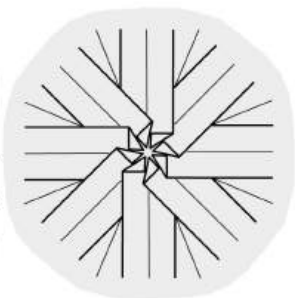

30 piega il centro
fold the center

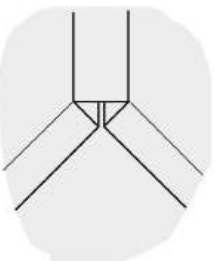

32 applica biforcazioni a 90°
apply 90° splits

spero apprezzerai
le figure intermedie /
I hope you'll enjoy
the intermediate steps



31

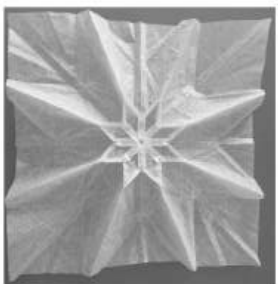

33

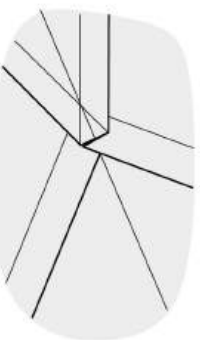

34 applica incroci a 90°
apply 90° crosses

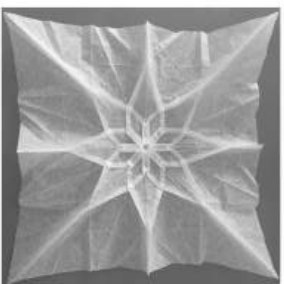

35

ancora
again

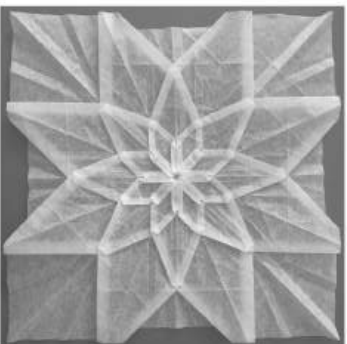

36

tassellazione radiale a simmetria 8
radial tessellation with symmetry 8



Tassellazione a rosone a simmetria 12
Rose window tessellation with symmetry 12

RG, febbraio 2012
 difficoltà 1 2 3 4 5
 usa un quadrato di almeno 30 cm
 use a square at least 12 inches (30 cm)

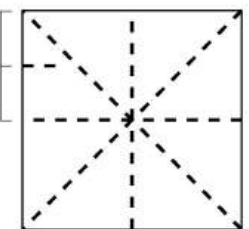

1 colore sotto, piega e riapri
color down, precrease

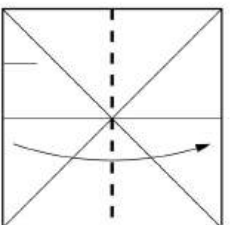

2

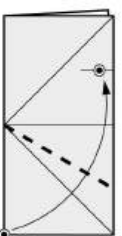

3 piega a 60°
60° fold

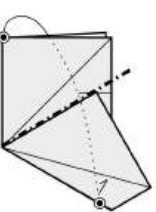

4 piega a 60°
60° fold

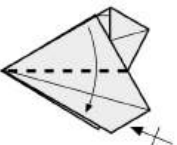

5 bisettrice
bisect

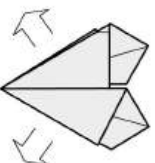

6

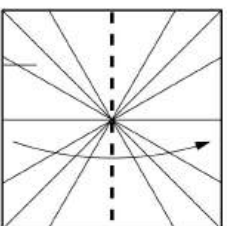

7 [7-9]

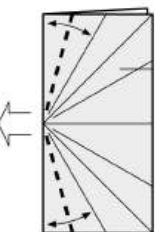

8 bisettrici
bisect

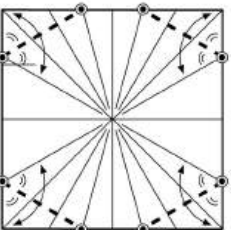

9 doppi punti di riferimento
double reference points

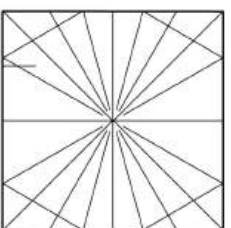

10

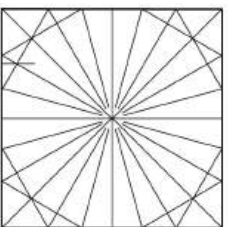

11

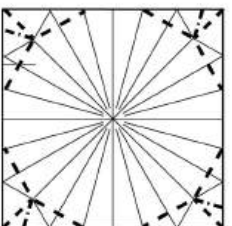

12 orecchi di coniglio
rabbit ears

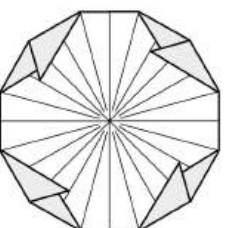

13 dodecagono regolare
regular dodecagon



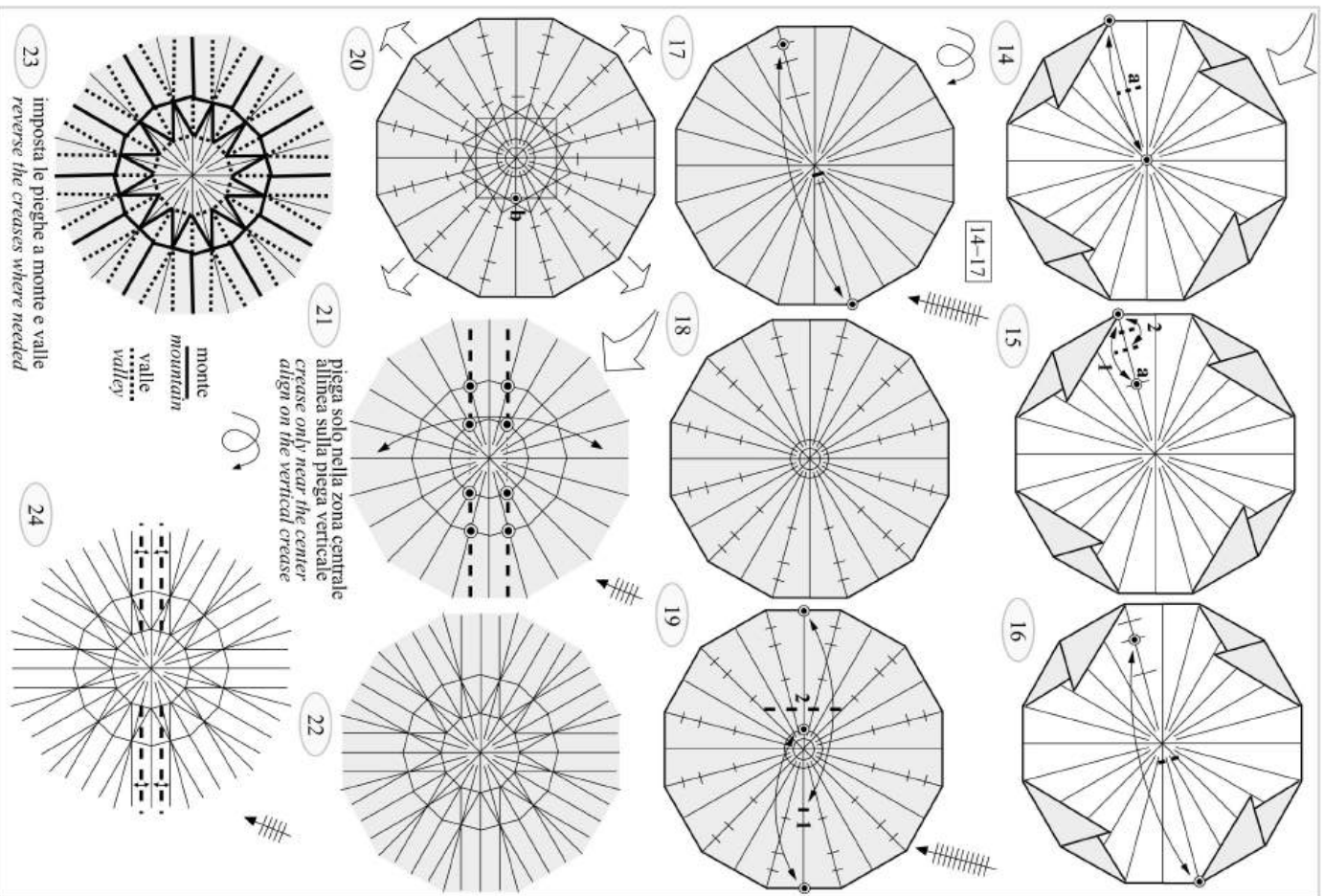

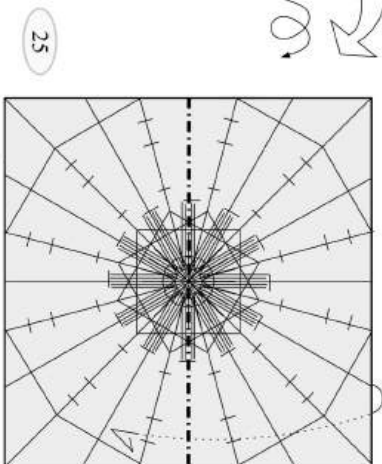

25

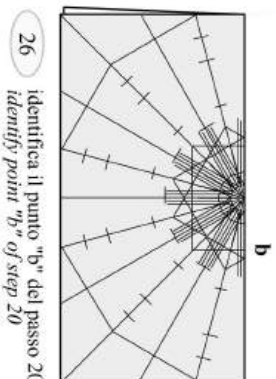

26 identifica il punto "b" del passo 20
identify point "b" of step 20

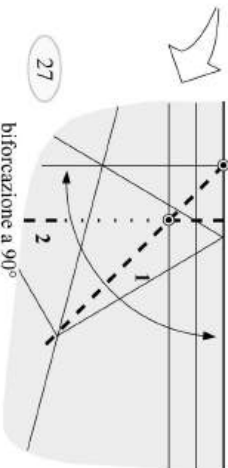

27

biforcazione a 90°
90° split

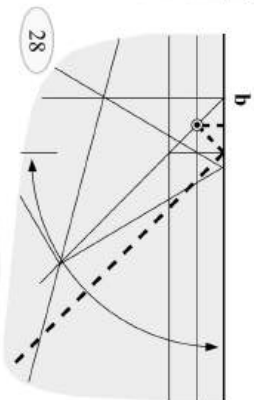

28

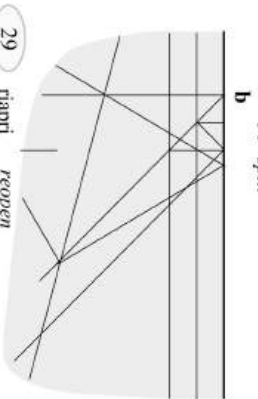

29

riapri
reopen

monte
mountain
valle
valley
imposta le pieghe
a monte e valle
reverse the creases
where needed

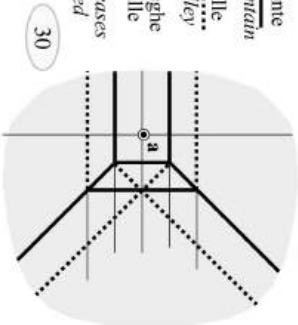

30

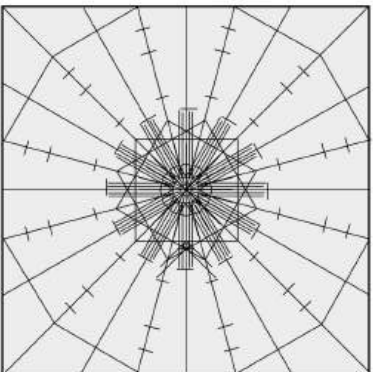

31



25-30

32

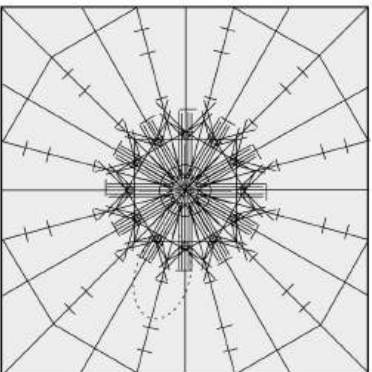

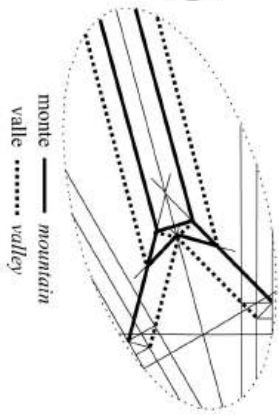
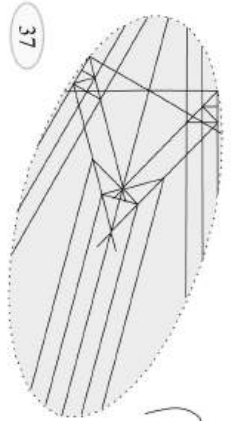
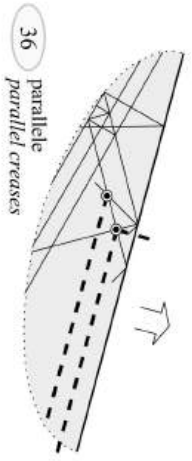
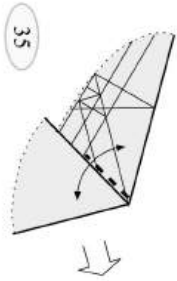
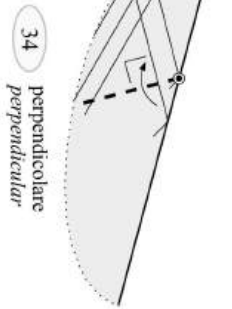
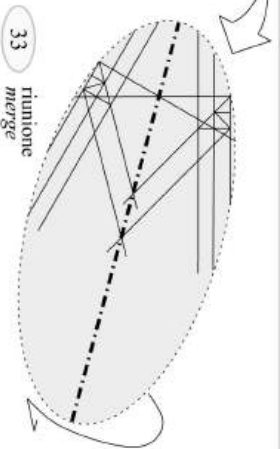

33-38

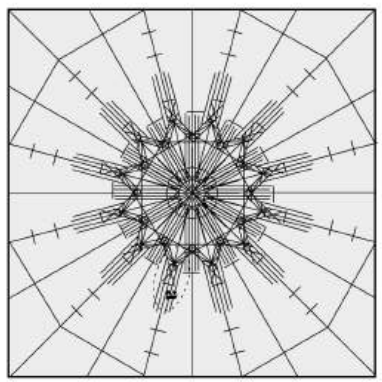
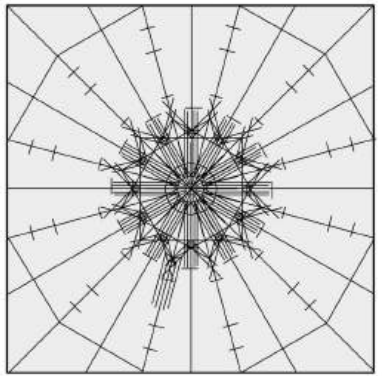

40 identifica il punto "a" del passo 14 identify point "a" of step 14



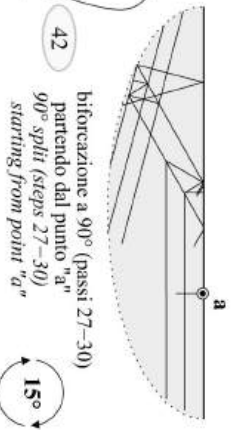
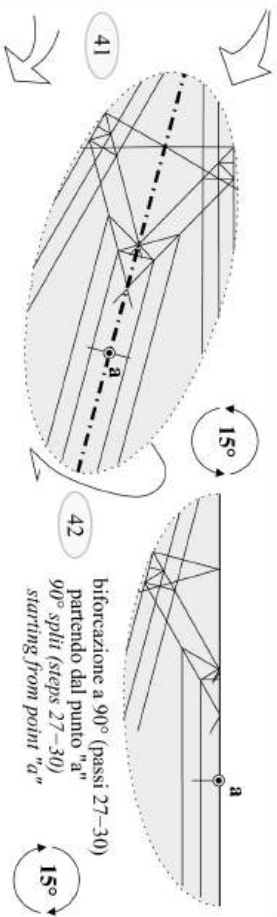

biforcuzione a 90° (passi 27-30)
partendo dal punto "a"
90° split (steps 27-30)
starring from point "a"

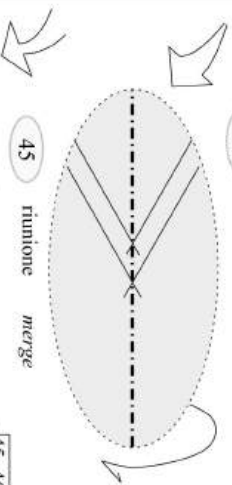
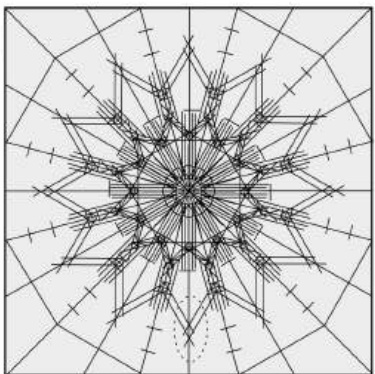
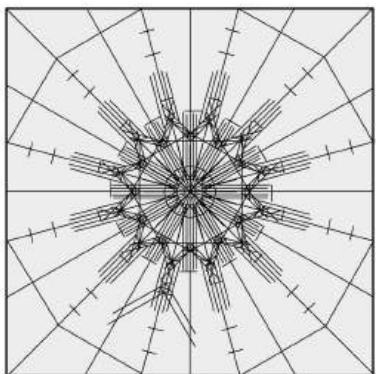

45 riunione merge



46 ripeti i passi 34-38
repeat steps 34-38

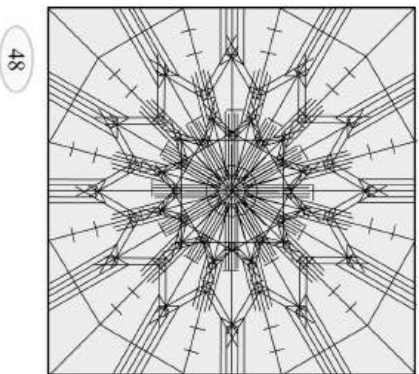
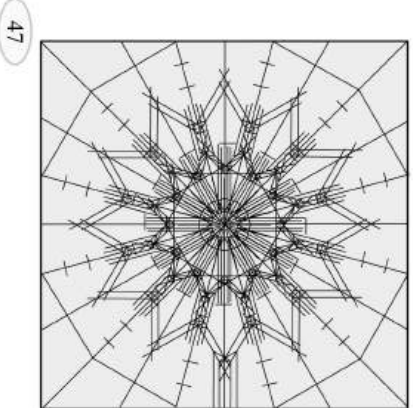

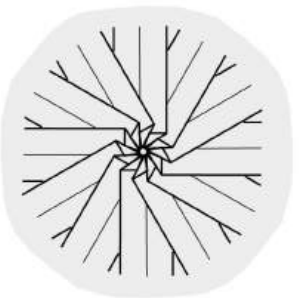

49 piega il centro (passo 23)
fold the center (step 23)

50

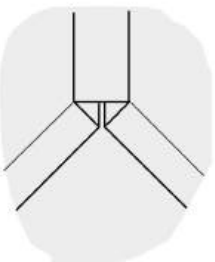
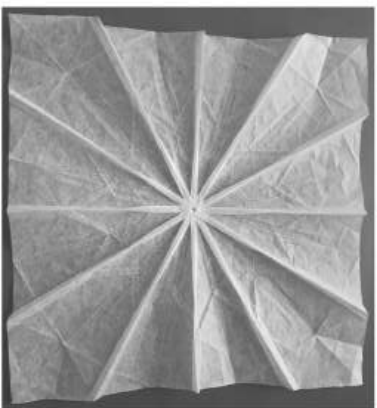

51 applica biforcazioni a 90°
apply 90° splits

52

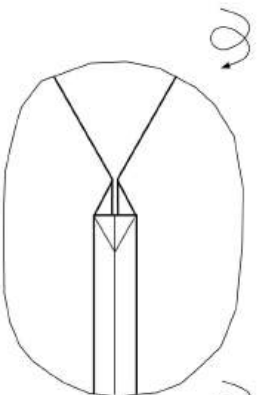
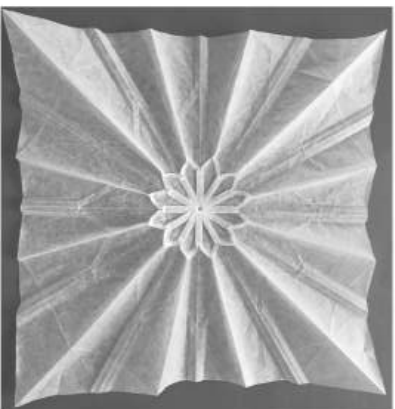

53 applica riunioni
apply merge

54

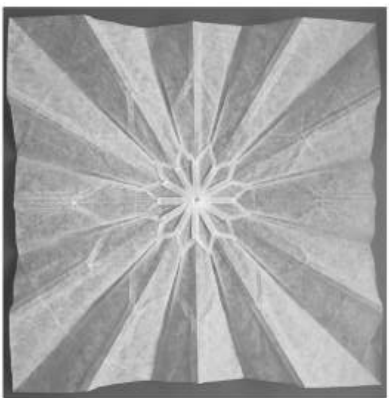

spero apprezzari
le figure intermedie /
I hope you'll enjoy
the intermediate steps

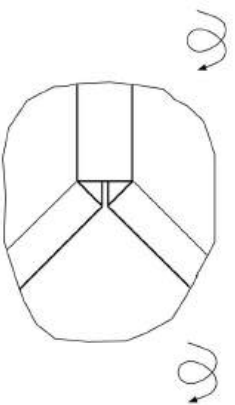

55 applica biforcazioni a 90°
apply 90° splits

56

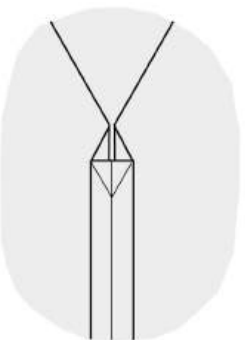

57 applica riunioni
apply merge

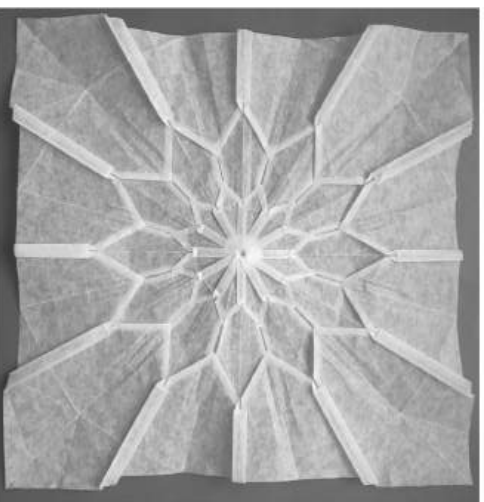

58 tassellazione a rosone a simmetria 12
rose window tessellation with symmetry 12



Pieghe curve - Curved creases

Tra le varie sperimentazioni che ho provato, una delle mie favorite coinvolge le pieghe curve. Pieghe curve costringono almeno parte della carta a formare superfici curve, che per me hanno particolare bellezza e fascino. Va detto che superfici curve possono essere ottenute anche con sole pieghe dritte, basti pensare ad un cono ottenuto con un normadissimo crimp.

Nel 2004 ho lavorato ad una serie di vasi aventi strutture simili: un poligono regolare di N lati al centro del foglio con una serie di pieghe radiali, in parte curve, che partono da ogni vertice del poligono e raggiungono l'estremità della carta. Le prime prove erano fatte al computer, semplicemente disegnando una coppia di pieghe monte-valle partenti da un vertice, quindi copiandole identiche ma ruotate attorno al centro del poligono. Stampare il disegno così ottenuto permetteva di avere una traccia da usare per verificare che tipo di struttura 3D si riuscisse ad ottenere, e di intuire la relazione tra il crease pattern - in particolare quanto e come si allontanassero tra loro le pieghe - e il risultato piegato, a volte impossibile senza distorsioni nella struttura risultante. La figura evidenzia in diversi punti della curva come la carta dovrà piegarsi, come risulterà (indicativamente) il diametro e quindi la forma del vaso.

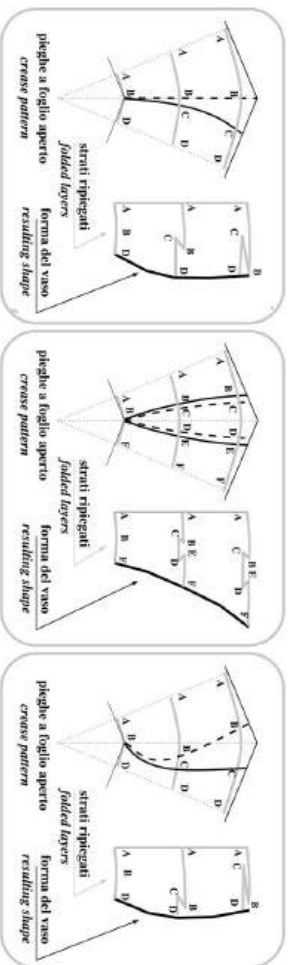

One of my favorite tests involves curved creases. They force at least part of the paper to form curved surfaces, which to me are of particular beauty and charm. It must be said that curved surfaces can be obtained with straight folds too, just think of a cone obtained with a crimp.

In 2004 I worked on a set of vases which have similar structures: a regular polygon with N sides in the center of the sheet, with radial folds starting at each vertex of the polygon and reaching the border of the paper. The first tests were made at the computer, simply drawing a pair of mountain-valley folds which start from a vertex, then rotating and copying them around the center of the polygon. Printing this figure allowed to easily fold it and verify which type of 3D structure would result, and to guess the relationship between the crease pattern - in particular how much and how the creases move away from each other - and the folded result, sometimes impossible without distortion in the resulting structure. The figure highlights in different points how the paper should fold, which will be the resulting diameter and hence the form of the vase.

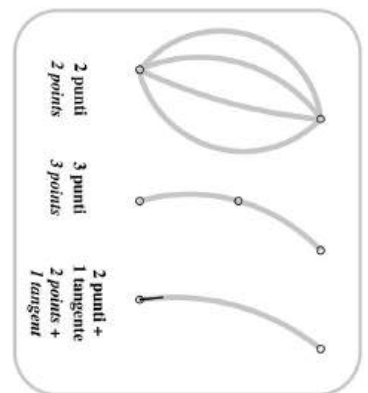

Una volta impraticatomi con le pieghe realizzate seguendo la traccia stampata, ho cominciato a pormi il problema di realizzare la stessa struttura sul foglio pulito - senza stampare - e mi sono subito reso conto dell'importanza di avere più punti di riferimento nella curva da piegare (soprattutto dovendo realizzare N pieghe il più possibile simili tra loro). Siccome esistono infinite curve che uniscono un punto di partenza a uno di arrivo, servono altre informazioni per replicare N volte una data curva. Ce ne sono di due tipi: *la curva deve passare per un certo punto* oppure *la curva deve partire con una certa direzione*. Queste informazioni aggiuntive sono sufficienti per individuare ad esempio un arco di cerchio, che è definito da *tre punti* oppure da *due punti e la tangente ad uno dei due punti*, ma possono comunque aiutare negli altri casi. Siccome trovare dei punti nelle traiettorie delle numerose curve può essere lungo e produrre troppe pieghe di lavoro che peggiorano il risultato finale, conviene quando possibile definire la direzione di partenza e di arrivo delle curve.

Once mastered the technique by folding the printed crease pattern, I wanted to get the same result on the clean sheet - without printing - and I quickly realized the importance of having several reference points in the curve to fold (especially having to fold N very similar curves). As there are infinite curves that join two points, more information is needed to replicate a given curve. There are two types of additional information: the curve must pass through one point or the curve has to start with a certain direction. For instance, the arc of a circle is defined by three points or by two points and the tangent to one of them. Since finding points in the trajectories of several curves can be long and produce too many creases that worsen the final result, when possible the direction of departure and arrival curves should be used.

La mia esperienza mi dice che una piega curva va fatta a monte, piegando in aria senza appoggiarsi su un piano. Il foglio di carta deve essere preferibilmente aperto, ogni sua parte va sistemata in modo da essere funzionale alla singola piega che si vuole realizzare. La piega prima va *imposta* cercando di utilizzare in maniera armonica tutti i punti di riferimento disponibili, quindi va *finalizzata* premendo unghia del pollice contro polpastrello dell'indice, un tratto alla volta. Dovendo realizzare vasi, conviene piegare in rapida successione tutte le pieghe identiche - le dita ricordano cosa fare da una piega alla successiva e il risultato sarà più omogeneo - quindi passare al prossimo gruppo di pieghe.

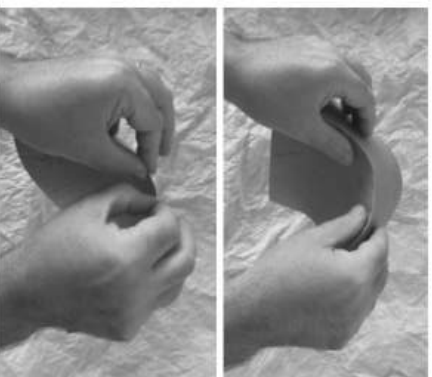

My experience tells me that a curved crease should be done in mountain style, folding in the air. The sheet of paper must preferably be opened, each part must be instrumental to the single crease that you want to fold. The fold should be first set trying to use in a harmonious way all the available reference points, then it should be finalized by pressing the nail of the thumb against the index finger, a piece at a time. Having to fold vases, it is better to fold all identical creases first - fingers remember what to do and the result will be more consistent - and then pass to the next group of folds.



Una maniera completamente diversa di ottenere curvature consiste nel piegare tassellazioni. Spesso tassellazioni portano la carta ad avere maggiori gradi di libertà e a potersi disporre in configurazioni pazzesche, dando origine a figure astratte di bellezza portentosa.

A completely different way to obtain curvature consists in folding tessellations. Tessellations often allow the paper to have more degrees of freedom, so it can assume crazy configurations, giving rise to abstract figures having marvelous beauty.

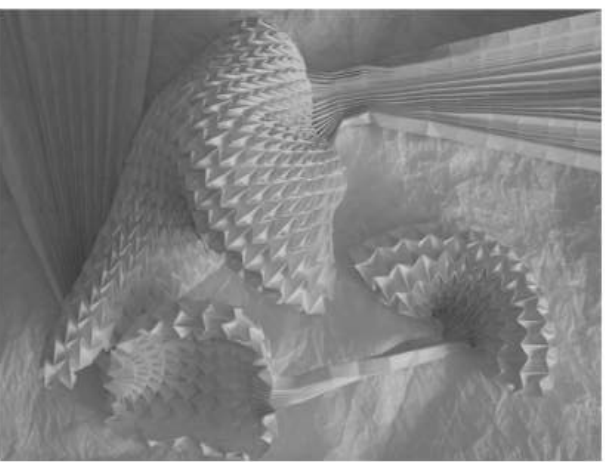
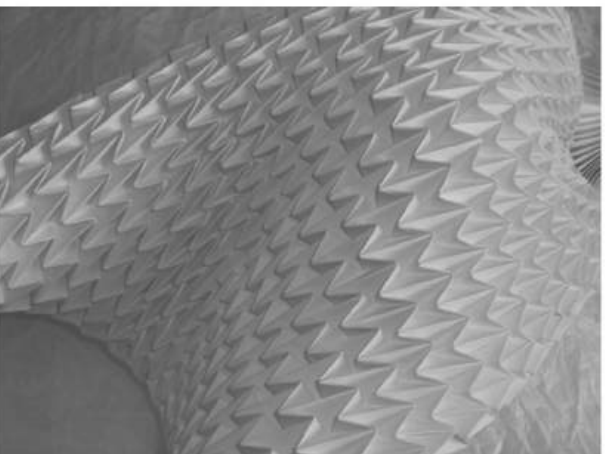
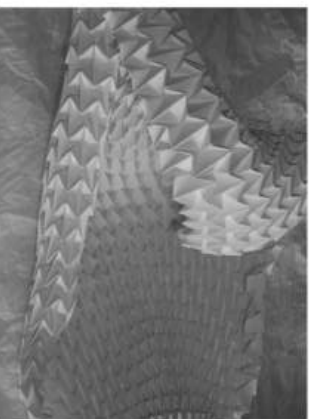

Vaso di Ginevra

Genève vase

RG, febbraio 2006
difficoltà 1 2 3 4 5

per evitare di avere pieghe dove la carta dovrà essere arrotondata, si usano pieghe immaginarie, che sono molto lievi... un po' come solo immaginare di piegare!
to avoid creases where the paper will curve, imaginary folds will be used:
they consist in very light creases... just imagine to fold!

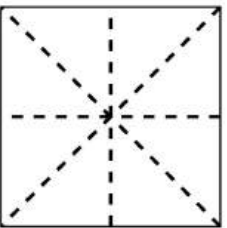

1 pieghe immaginarie
imaginary folds

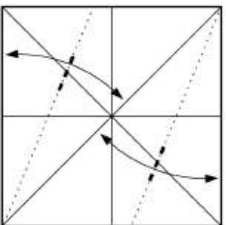

2 bisettrici: segni immaginari
bisect: imaginary pinch

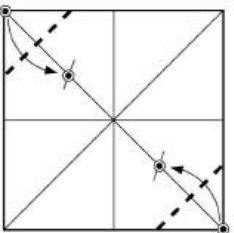

3 pieghe reali
real folds

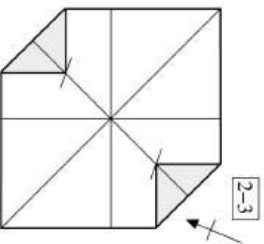

4

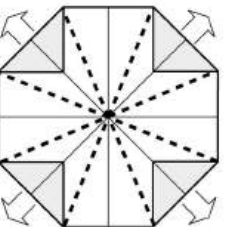

5 ottagono regolare; pieghe reali
regular octagon: real folds

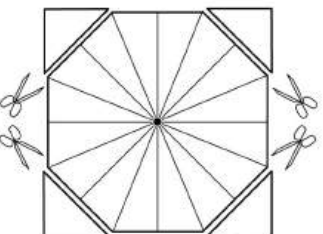

6 taglia la carta in eccesso
cut excess paper

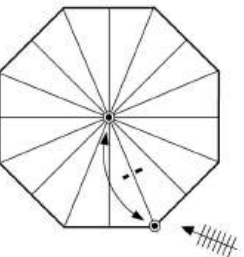

7 segni reali
real pinch

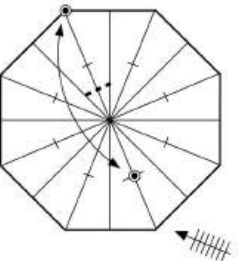

8 pieghe reali
real folds

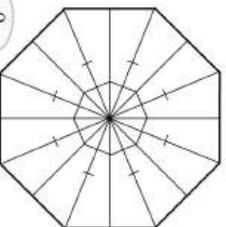

9



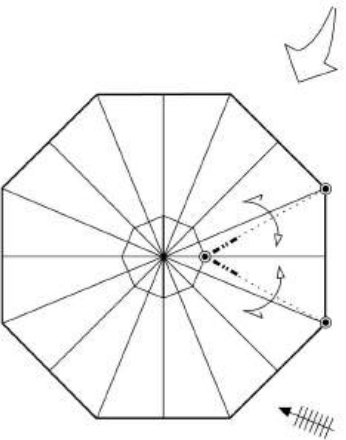

10 piega solo dove indicato
fold only where indicated

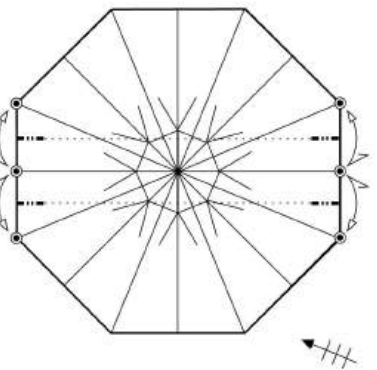

11 piega solo dove indicato
fold only where indicated

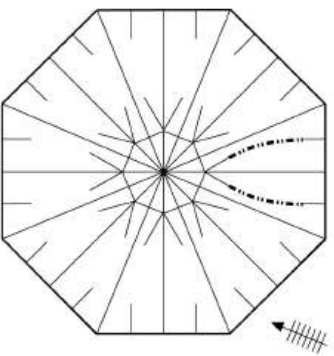

12 unisci con una piega curva
join segments with a curved crease

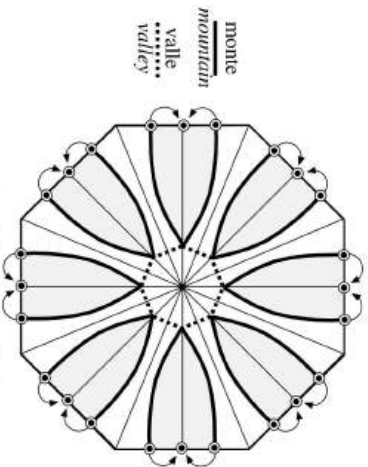

13 alza i lati, unendo all'esterno i punti indicati: le aree scure vanno arrotondare all'esterno
raise the sides, joining at the extern the indicated points: grey areas need to be curved outside

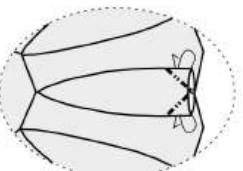

14 vista da fuori: appiattisci in alto e bloccala con pieghe a monte
outside view: make the top flat and lock with mountain folds

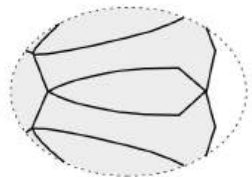

15

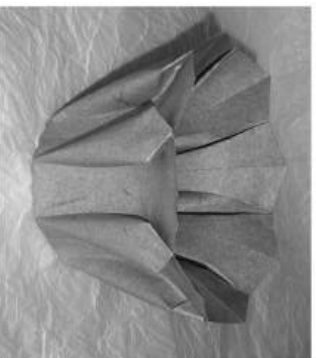
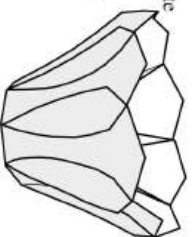

VASO di GINEVRA
Genève vase



Botte

Cask

RG, inizio 2009
difficoltà 1 2 3 4 5

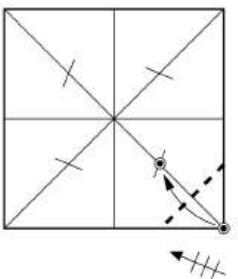
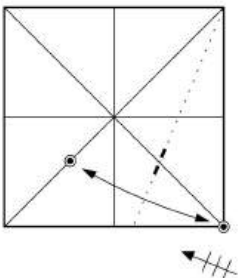
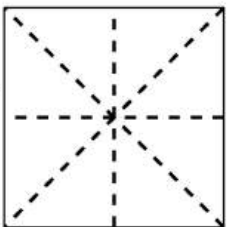

1 colore sotto, prepiega
color down, precrease

2

3

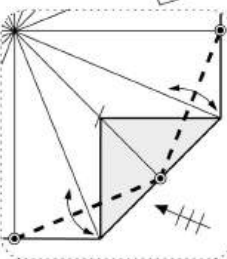
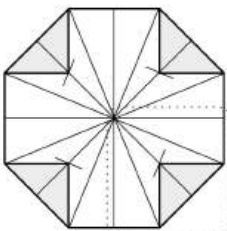
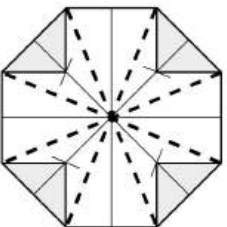

4 ottagono regolare
regular octagon

5

6

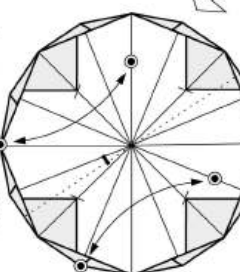
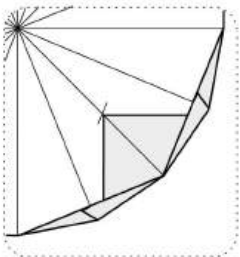
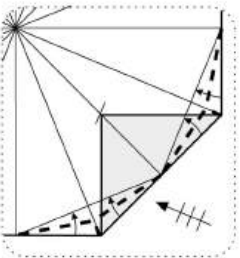

7 bisettrici, orecchi di coniglio
bisectrs, rabbit ears

8

9

poligono regolare a 16 lati
allinea sulla bisettrice immaginaria
regular 16-sided polygon
align on the imaginary bisector

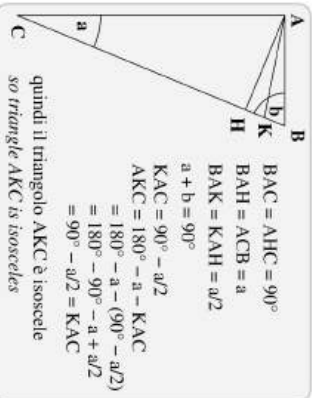

quindi il triangolo AKC è isoscele
so Triangle AKC is isosceles

10

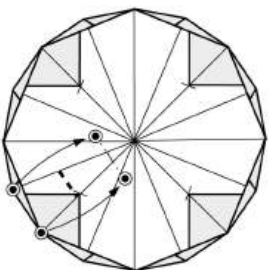

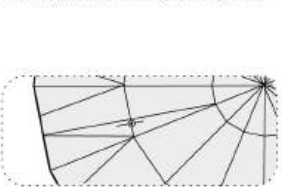
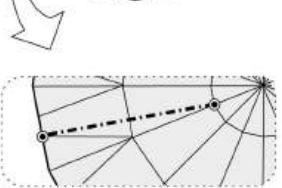
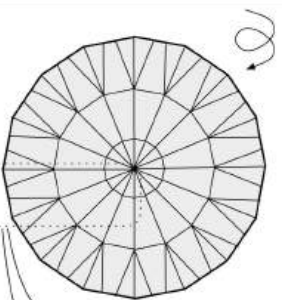
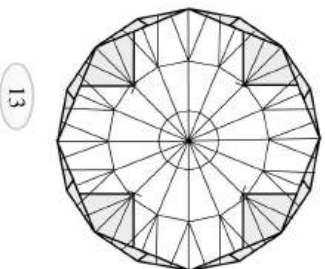
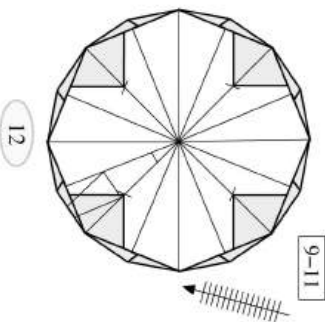
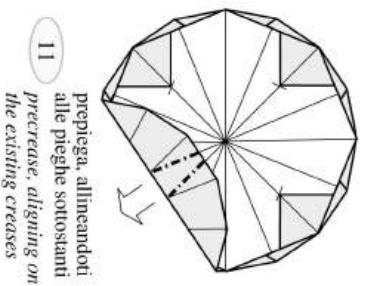

14

15

16

17

piega morbida
crease softly

circa un quarto
about one fourth

piega curva
curved crease

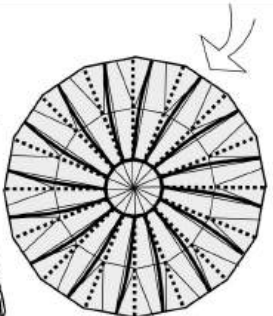

18

collassa
collapse

monte
mountain
valle
valley

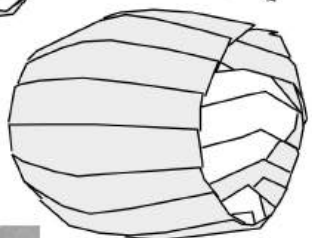

20



3D

collassa
collapse

blocca ogni segmento con pieghe a monte all'interno
lock every segment with internal mountain folds



Vaso #15 – crease pattern
Vase #15 – crease pattern

RG, 2004
difficoltà 1 2 3 4 5

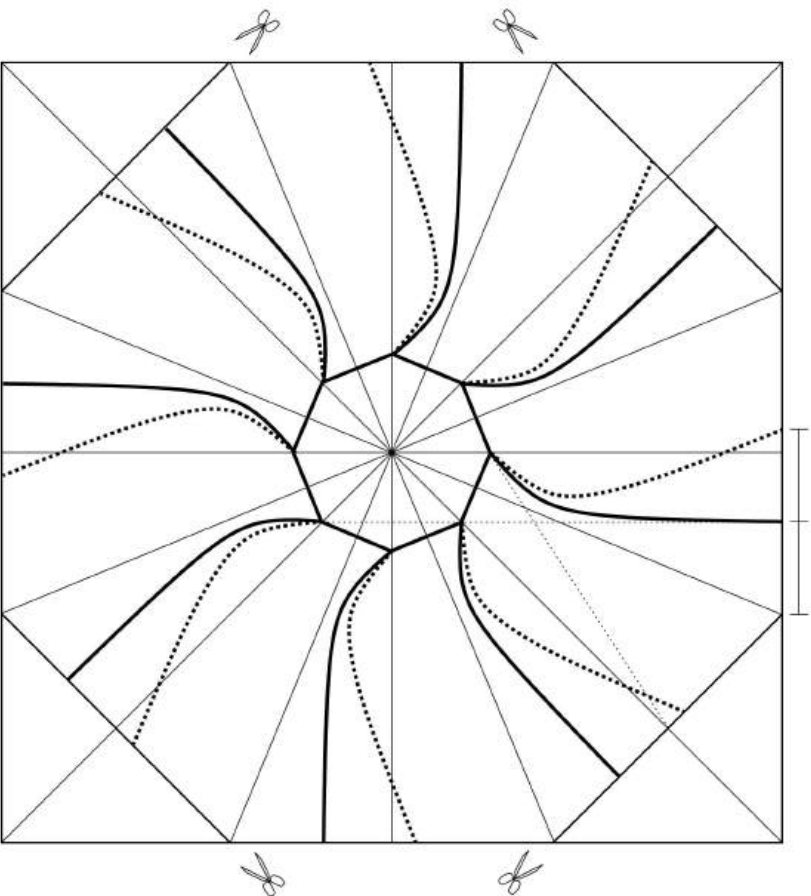

monte — mountain
valle valley
tangente tangent

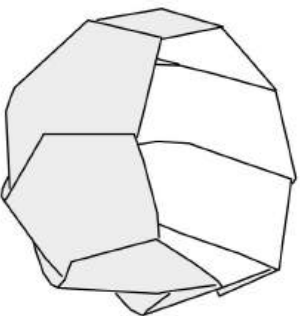

Vaso #4 – crease pattern
Vase #4 – crease pattern

RG, 2004
difficoltà 1 2 3 4 5

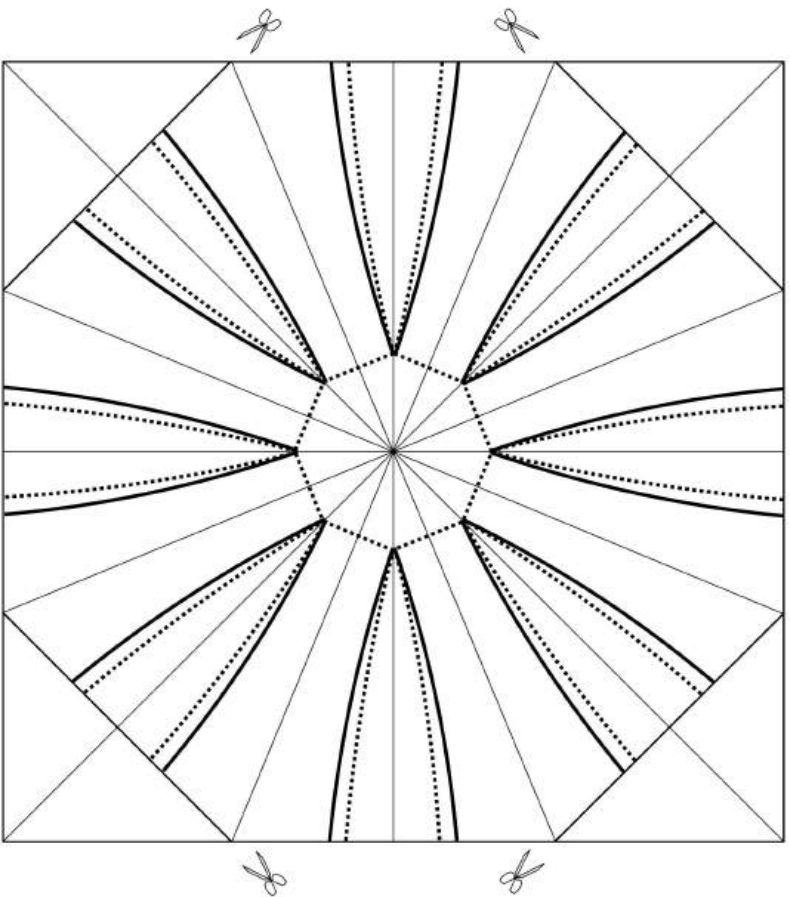

monte — mountain
valle valley

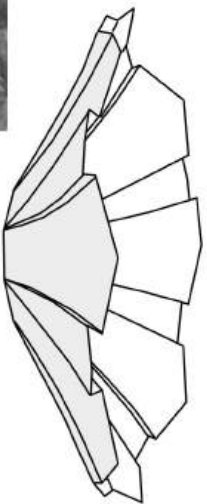

Vaso #2 – crease pattern
Vase #2 – crease pattern

RG, 2004
difficoltà 1 2 3 4 5

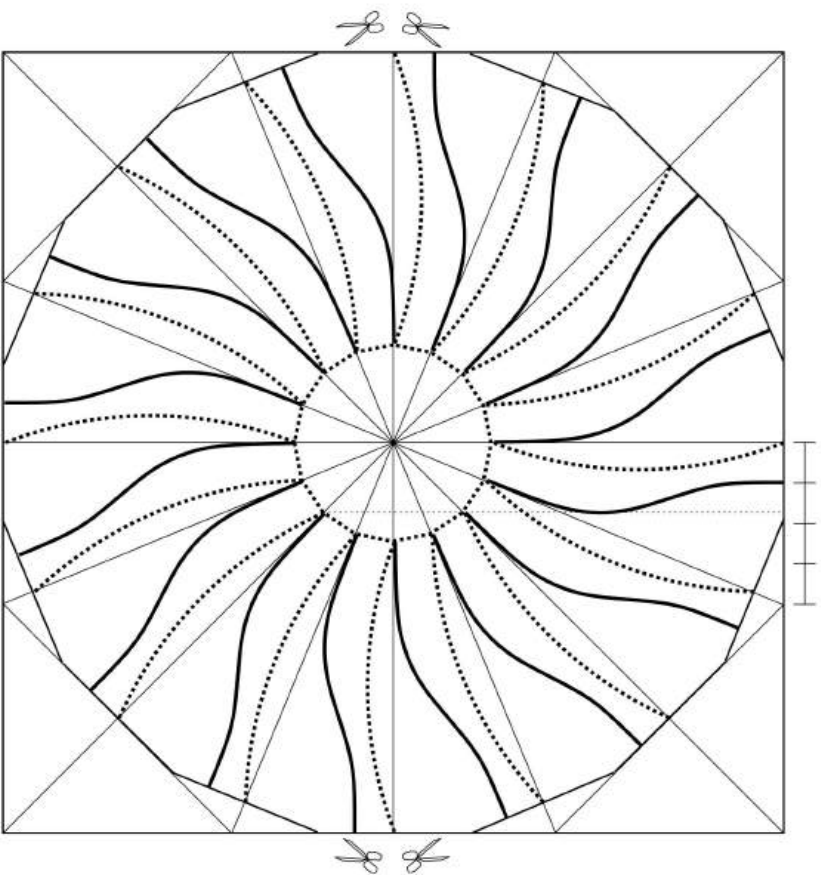

monte — mountain
valle valley
tangente tangent

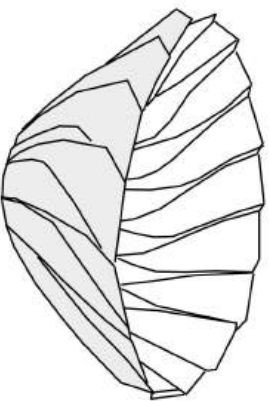

Pieghe stropicciate – *Crumpled folds*

Stropicciare la carta ha un che di liberatorio. Tanti chiedono se anche questa tecnica possa essere considerata origami, e io direi senza alcun dubbio di sì. Si tratta di una tecnica veloce, che permette di ottenere risultati incredibili quando si tratti di rappresentare specialmente funghi e piante. Stropicciare una punta equivale, tecnicamente, a realizzare una serie di sink che di fatto non fanno altro che assottigliare delle punte. La carta con cui si realizzano questo tipo di modelli è una carta da pacco molto sottile (28 gr/mq) e molto grande (esistono bobine larghe 1,2 metri e pesanti decine di chili, portate per la prima volta ai convegni italiani da Paul e Annette Hassenforder).

Per quanto riguarda la struttura dei modelli, i crease pattern rappresentano perfettamente quello che si vuole ottenere, e anzi è possibile piegare con la tecnica della carta stropicciata qualsiasi altro modello. Ad esempio ho piegato in pochi minuti una versione stropicciata del mio Caproni CA 100, un biplano idrovolante. Si tratta di un modello origami complesso, che io normalmente piego in 2 o 3 ore. Usare la carta stropicciata in effetti può portare ad una nuova tecnica di progettazione di origami, vista la facilità con cui è possibile cambiare posizione o lunghezza di una punta per togliere o dare carta alle punte vicine. Una specie di alternativa low-cost a Treemaker, se uno non ha il computer sottomano.

Crumpling technique is great. Many people ask whether this technique can be considered origami, and I'd say without doubt yes, it is. It is a fast technique, which allows to obtain outstanding results especially with mushrooms and plants. To crumple a point is technically equivalent to fold a lot of sinks that basically make the point thinner. The paper used for this kind of models is a wrapping paper which is very thin (28 g/sqm) and very large (there are coils 1.2 meters wide which weigh tens of kilograms, available to some past CDO conventions thanks to Paul and Annette Hassenforder).

Concerning the structure of the models, crease patterns represent exactly what you want to achieve, and indeed with this technique it is possible to fold any complex model. For example, I folded in a few minutes a version of my Caproni CA 100, a biplane seaplane. It is a complex model that normally I fold in 2 to 3 hours. Using crumpling technique in fact leads to a different way of designing origami, given that it is quite easy to change position or length of a point, in order to take or give paper to the near points. A kind of low-cost alternative to Treemaker, if one does not want to use the computer.



Una bella sfida era stata quella di partecipare al concorso *ordine contro caos* (Chaos vs. Order) in cui avevo presentato una struttura a nido d'ape - l'ordine - che via via si trasformava in una struttura caotica che sfociava in un vulcano - il caos. La parte dell'ordine era piegata in maniera normale, mentre quella del caos usava la tecnica della carta stropicciata.

A nice challenge was to enter the contest Chaos vs. Order where I presented a honeycomb structure - the order - which was gradually transformed into a chaotic structure which resulted in a volcano - the chaos. The part order was folded normally, while that of chaos used the crumpled technique.



Con questa tecnica presento alcuni alberi, due dei quali sono frattali. La maniera forse più naturale di piegare un albero consiste nell'usare il centro del foglio per il tronco, e il bordo del foglio per i rami, ottenendo un robusto tronco e rami snelli, il che per un albero è una buona scelta. Ma dopo un po' di ragionamenti mi ero convinto che un vero albero è frattale, e così dovrebbe essere la sua versione origami. Questa considerazione mi ha portato ad una struttura completamente diversa, in cui il tronco sfrutta l'esterno del foglio mentre i rami si sviluppano all'interno. Questa scelta porta ad alberi francamente meno belli dei precedenti, perché posizionare i rami all'interno porta a punte più spesse... ma mi piace pensare che forse è solo un limite della carta che viene utilizzata.

With this technique I present here some trees, two of which are fractals. Probably, the most natural way to fold a tree is to use the center of the sheet for the trunk, and the edge for the branches, obtaining a robust trunk and slender branches, which is a good choice for a tree. But after some reasoning I was convinced that a real tree is fractal, and so should be his origami version. This consideration led me to a completely different structure, in which the trunk exploits the outside of the sheet while the branches are inside. This choice leads to less attractive trees than the previous ones, because the branches are too thick... but I like to think that it is just a limit of the paper.

Tecnicamente, la carta viene prima piegata nella maniera tradizionale per trovare i riferimenti necessari e identificare le pieghe principali (pieghe di struttura), quindi viene stropicciata cercando di effettuare pieghe lungo la direzione delle varie punte. Quindi viene aperta, bagnata con uno spruzzatore, richiusa e stropicciata: la sequenza di riaprire, richiudere e stropicciare viene ripetuta diverse volte, finché le mini pieghe non diventano quasi regolari.



49

From a practical point of view, the paper is first folded in the traditional way to find out the reference points needed for the structure of the model, then it is crumpled trying to form creases in the direction of the points. At this point the paper is opened, wet with a sprinkler, closed and crumpled: the sequence reopen - reclose - crumple has to be repeated several times, until the minicreases become nearly regular.

Albero per novembre – create pattern
Tree for November – create pattern

RG, ottobre 2009
difficoltà 1 2 3 4 5

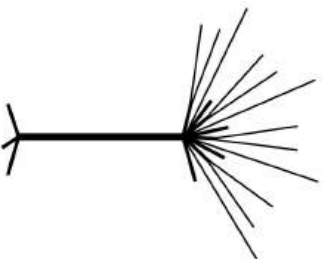
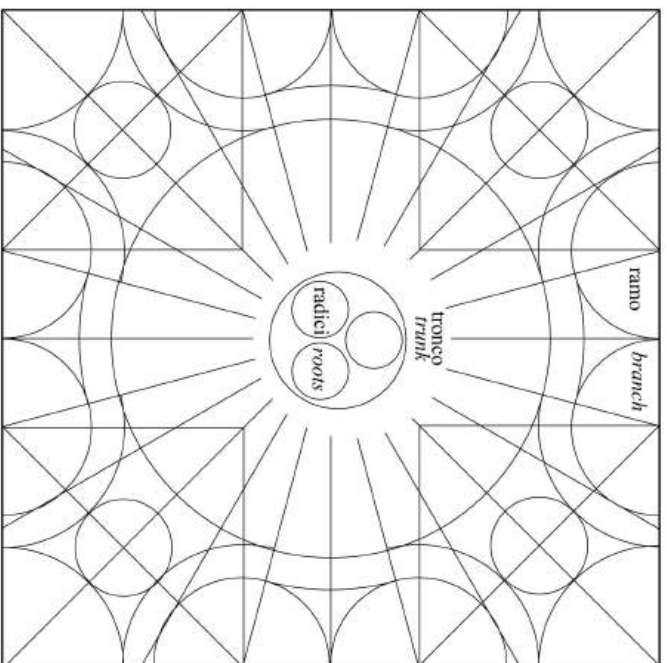

i rami sono tutti nella parte esterna del quadrato, quindi risultano molto sottili

all the branches are on the external part of the square, so they are quite thin

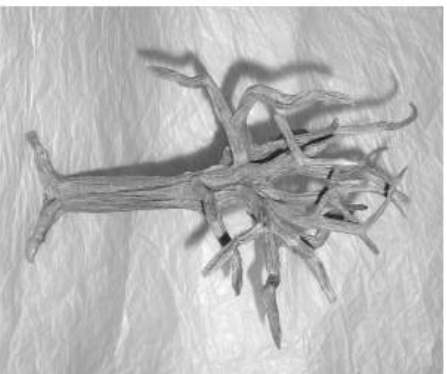

Albero per novembre
Tree for November

carta da pacco 28 gr/mq, cm 60 x 60
wrapping paper 28 g/sqm, 60 x 60 cm

RG, ottobre 2009
difficoltà 1 2 3 4 5

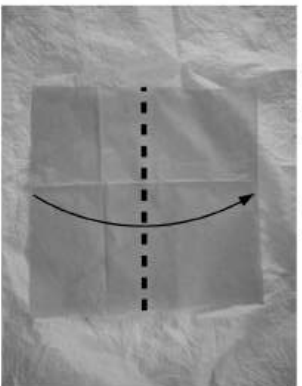

1

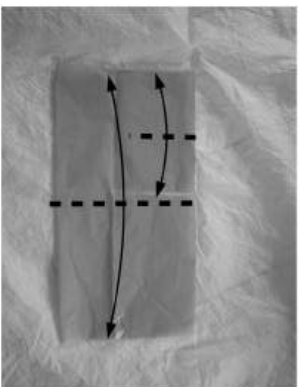

2

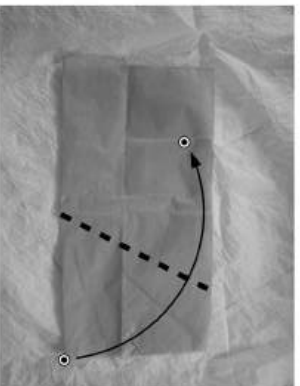

3

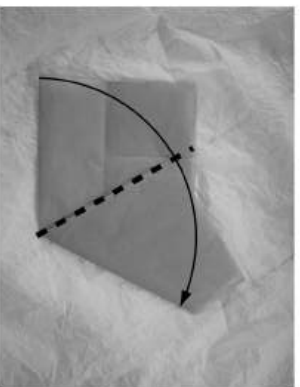

4

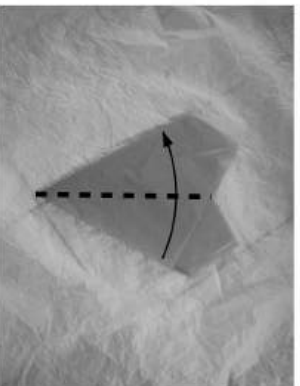

5

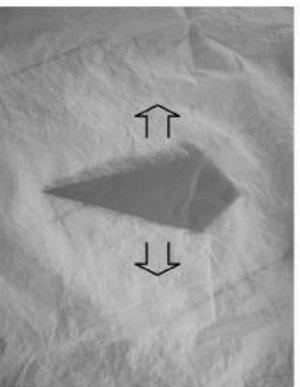

6

riapri al passo 3
reopen to step 3



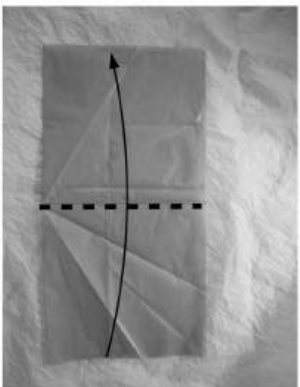

7

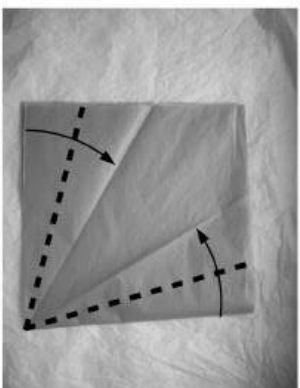

8

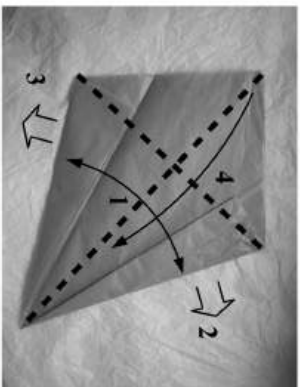

9

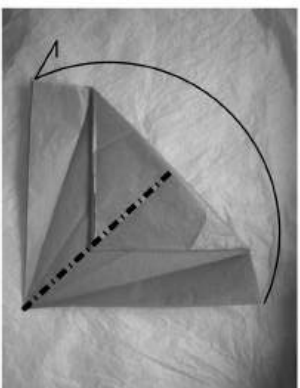

10

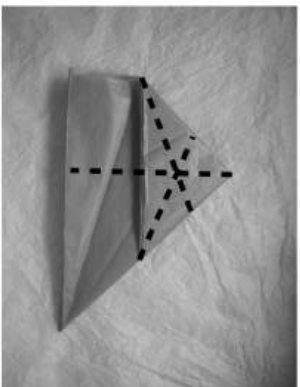

11

prepiega bisettrici
precrease bisectors



12

riapri al passo 8
reopen to step 8



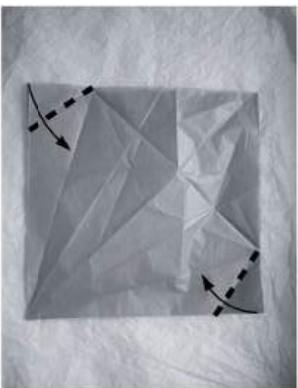

13
bisettici
bisectors

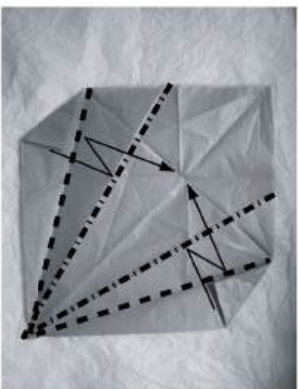

14
2 crimp
2 crimps

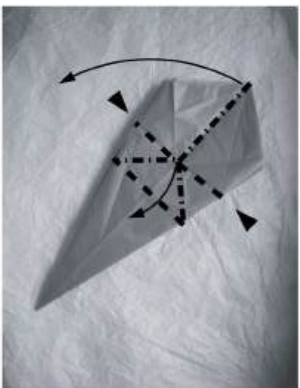

15
collassa come indicato
collapse as indicated

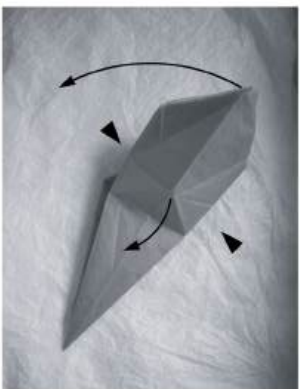

16
in corso
in progress

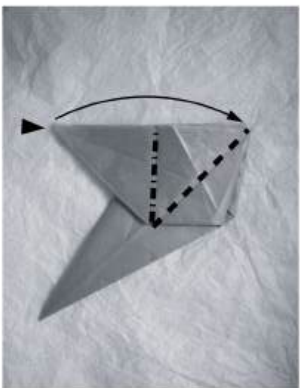

17
piega schiacciata
squash fold

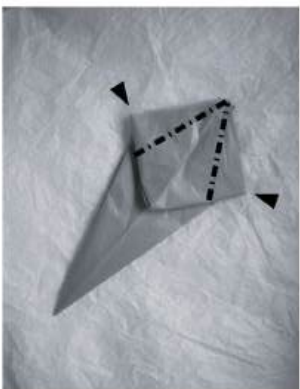

18
rovesciate interne
inside reverse folds

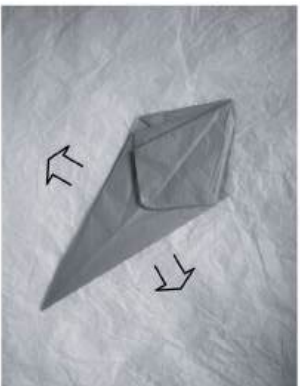

19 riapri tutto
reopen everything

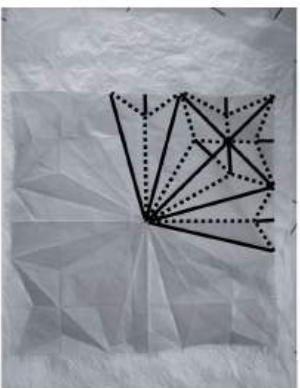

20 richiudi separando le punte
close again, pulling points apart



21 chiusura in corso...
in progress...



22 continua...
continue...



23 stroppiccia
crumple



24 apri, spruzza con acqua e richiudi
open, wet with water and close again

monte — mountain
valle valley





25



26

estrai la carta a formare un cerchio
extract all the paper to form a circle



27

forma 3 punte per le radici
form 3 points for the roots



28

separa tutti i rami
pull all branches apart



29

struttura ad albero
tree structure



30

ogni ramo può essere accorciato
per dare origine ad altri rametti...
*every branch can be shortened
to give rise to other little branches...*



31 i nuovi rametti sono visibili...
you can see the new little branches...



32 ramo con due rametti
branch with two little branches



33 modella ogni singolo ramo, aiutati
con laccetti metallici a tenerlo
in forma finché non asciugga
*model every branch, some metallic
wire keeps the form until it dries*

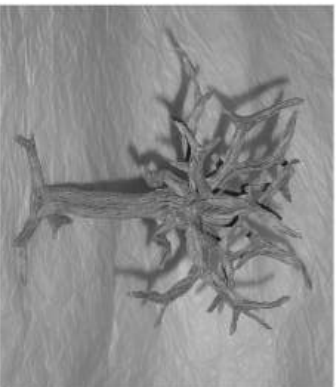

34

35

aprendo ogni ramo come al passo 30
puoi modellare alberi estivi...
*by opening each branch like at step 30
you can obtain some summer tree...*



Albero frattale 4x – crease pattern
Fractal tree 4x – crease pattern

RG, ottobre 2009
difficoltà 1 2 3 4 5

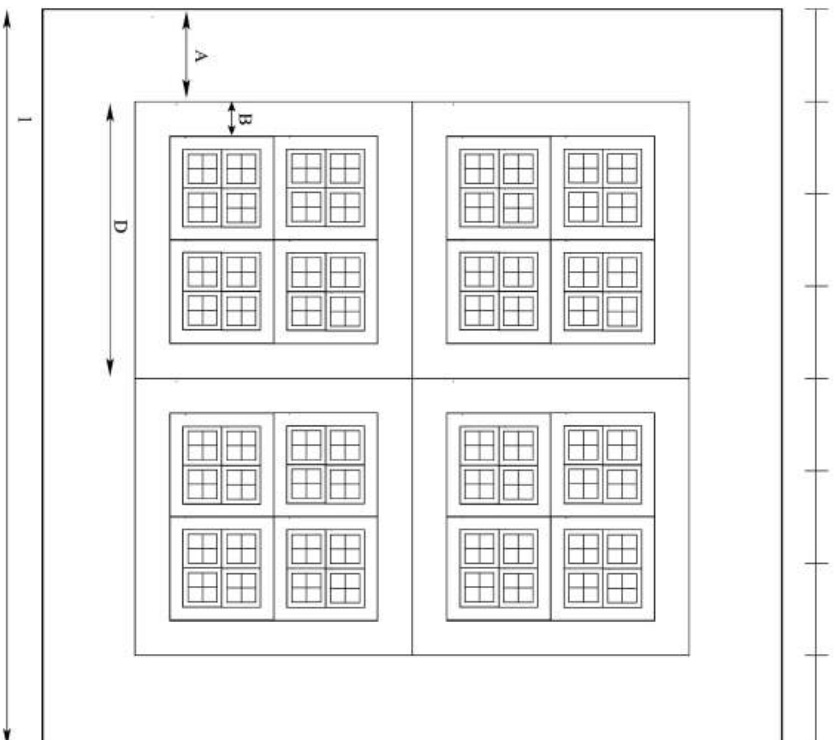

$$A / 1 = B / D$$
$$D = 1/2 - A$$
$$B = A * D = A/2 - A * A$$

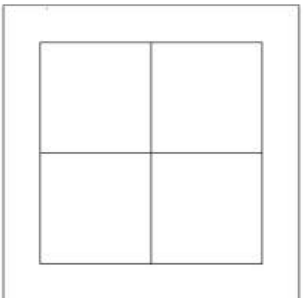
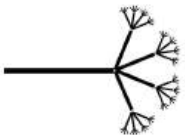

struttura ricorsiva
recursive pattern



Albero frattale 7x – crease pattern
Fractal tree 7x – crease pattern

RG, ottobre 2009
difficoltà 1 2 3 4 5

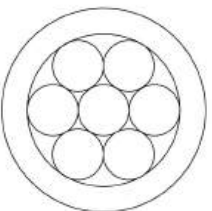
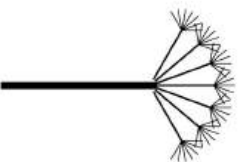
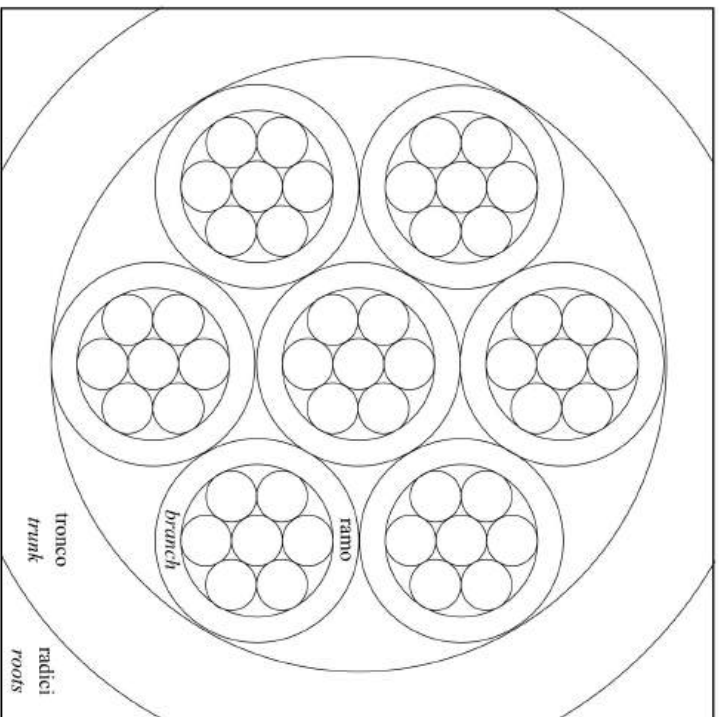

struttura ricorsiva
recursive pattern



Albero frattale 7x – iterazione
Fractal tree 7x – iteration

albero intero: carta da pacco 28 gr/mq, cm 120 x 120
whole tree: wrapping paper 28 g/sqm, 120 x 120 cm

RG, ottobre 2009
difficoltà 1 2 3 4 5

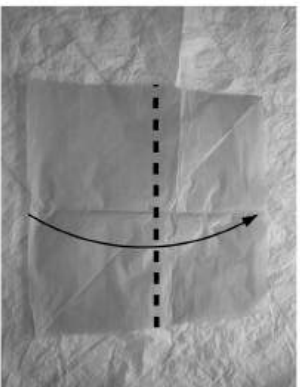

1 una iterazione: 60 x 60 cm
one iteration: 60 x 60 cm

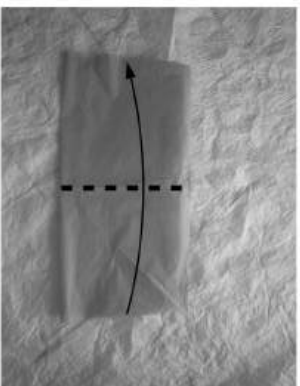

2

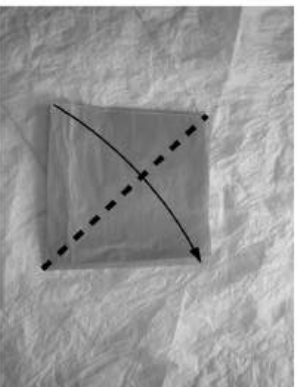

3

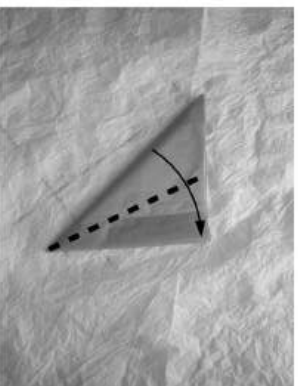

4



5



6





7
stropicciata tutta la punta
crumple all the point



8
risultato riaperto
opened result

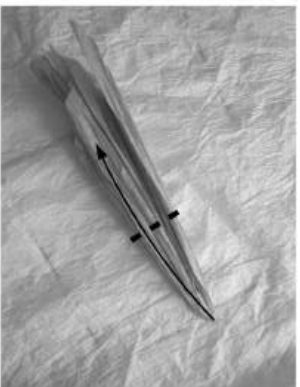

9
punta stropicciata
crumpled point



10

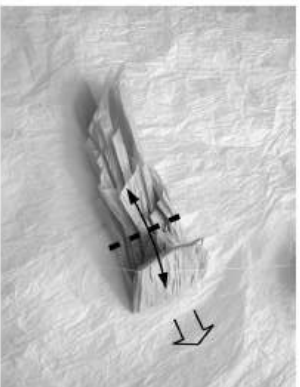

11



12



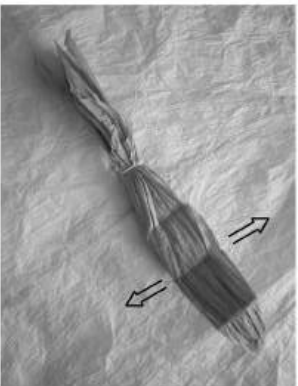

13
fissa il punto in basso con un
lacciato metallico, estrai tutta
la carta a formare un cerchio
*fix the base with a metallic wire
extract all the paper to form a circle*

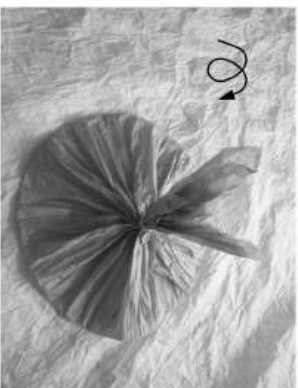

14
vista da sotto
bottom view

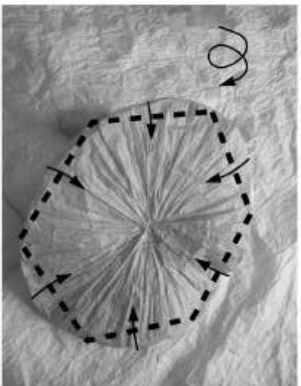

15
piega un esagono regolare
fold a regular hexagon

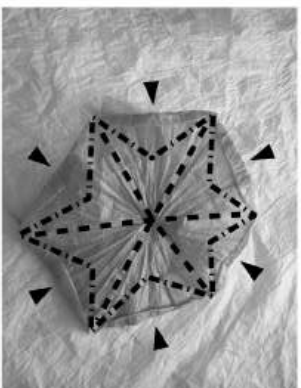

16
comincia a formare le 6 punte esterne
begin to form the 6 external points

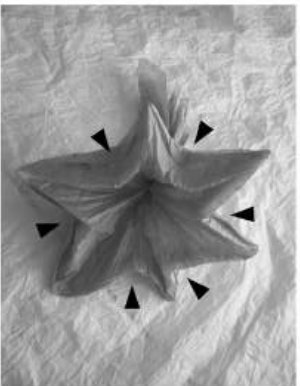

17
continua a chiudere le punte
continue closing the points



18
estrai la punta centrale
extract the central point



19 stropiccia le 7 punte
crumple the 7 points



20 ora riapri e spruzza con acqua
now reopen and wet with water



21 comincia a richiudere
start to close

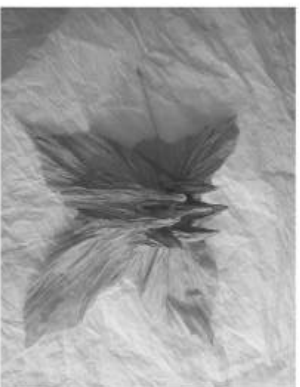

22 quasi fatto...
nearly done...



23 per la prossima iterazione, ripeti i passi da 9 a 23 sulle 7 punte...
for the next iteration, repeat steps from 9 to 23 on the 7 points...



24 albero frattale con 2 iterazioni
fractal tree with 2 iterations



Modelli qua e là – *Models here, there and everywhere*

In questo capitolo raggrupperò diverse categorie: modulari, figurativi, modelli che sfruttano il cambio di colore (segnalibro quadrifoglio, nontiscordardime, scatola con 8 cuori), potenziali gioielli (DNA), origami indossabili (elmo e armatura), origami che, ripiegati, con un singolo taglio danno origine a profili vari (le scritte HLT, CDO), che risultano essere un interessante esercizio per giocare coi crease pattern. Ci sono modelli semplici e difficili, oggetti ed animali. Alcuni modelli andrebbero piegati usando la tecnica del wet folding (angelo, pecora). Alcuni tra i più semplici potrebbero essere già stati inventati da altri a mia insaputa, può succedere: quando sono consapevole della somiglianza di un mio modello con un modello esistente (ad esempio il DNA, il fiore con la stella, la tassellazione della racchetta da tennis) lo dico esplicitamente. Nel mio inventario di modelli mancano - purtroppo - modelli di movimento: bisogna pur tenersi qualcosa da fare per quando si diventa vecchi, no?

Alcuni modelli forse non li diagrammerò mai, o perché troppo difficili o perché non li considero ancora definitivi, ma ogni volta che li piegherò risulteranno in qualche modo diversi. Citando uno dei personaggi dei film di Jack Sparrow, direi che a volte i diagrammi sono più che altro una traccia, piuttosto che una regola da seguire senza deviazioni. E' certamente il caso dell'albero di Natale e della racchetta da tennis. Per il triplano Fokker Dr 1 - l'aereo del Barone Rosso - invece si tratta di pigrizia, o meglio il non aver ancor trovato una sequenza di piegatura ripetibile. La frase *collassa tutto* rappresenta esattamente quello che succede quando piego un mio modello per la prima volta, ben prima di riuscire ad impacchettarlo in una sequenza di mosse ben definite.

In this chapter I collect several categories: modular origami, figurative models, color change, potential jewelry, wearable origami, origami that with a single cut give rise to different profiles, a very interesting exercise to practice with crease patterns. There are simple and difficult models, objects and animals. Some models should be folded using wet folding, and some of the simplest could have been already invented by other creators without my knowledge: when I'm aware of some similarity, I explicitly give credit to the original author (DNA, flower with a star, tessellation of the tennis racket). In my inventory, action models are unfortunately missing: one has to keep something for when he gets old, right?

Maybe, some of my models will never be diagrammed, either because they are too difficult or because I don't consider them finished yet: every time I fold them, there will be something different. To quote one of the characters of Jack Sparrow's movies, I would say that sometimes the diagrams are like a track, rather than a rule to follow without deviations. This is certainly the case of the Christmas tree and the tennis racket. For the triplane Fokker Dr 1 - the plane of the Red Baron - it is laziness, or better the fact that so far I've not yet found a repeatable folding sequence. The phrase collapse everything is exactly what happens when I fold one of my models for the first time, well before being able to pack it into a sequence of well defined moves.

Angelo
Angel

RG, novembre 2011
difficoltà 1 2 3 4 5

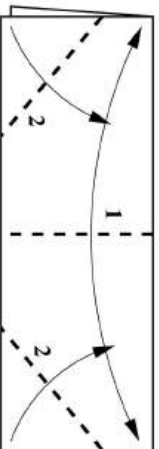
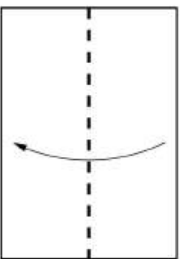

- 1 A5 o A6, cartoncino inumidito
A5 or A6, heavy paper, wet folded

- 2 piega al centro morbida: le altre a sentimento
fold in half softly; others have no reference

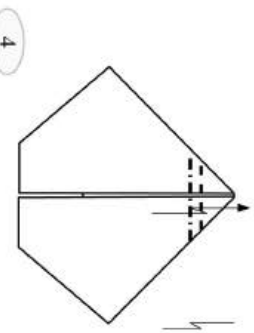
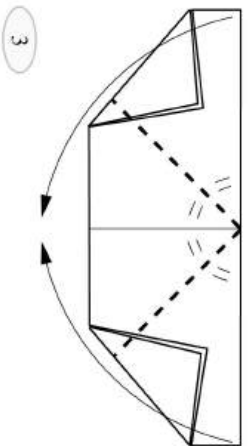

3

4

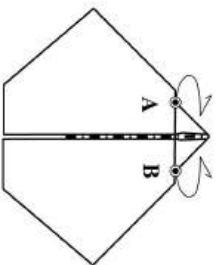

- 5 A deve toccare B, dietro
A must touch B, behind

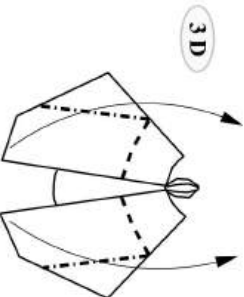

- 6 una specie di piega a petalo
a sort of petal fold

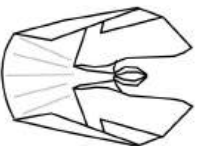

- 7 modella arrotondando ovunque
shape the angel

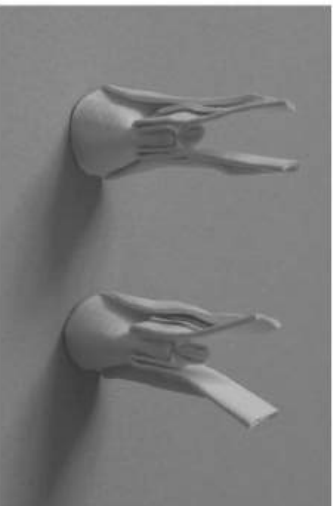

Segnaposto cuore
Heart place card

RG, agosto 2012
difficoltà 1 2 3 4 5

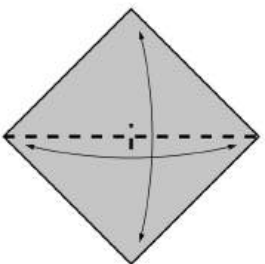

1

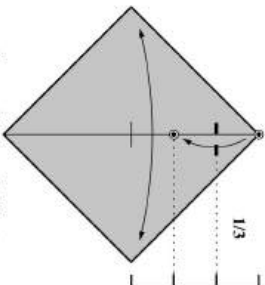

2
piega solo dove indicato
fold only where indicated

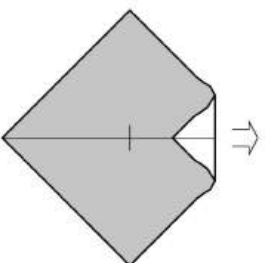

3

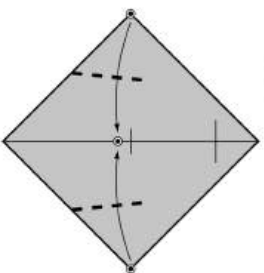

4
piega solo dove indicato
fold only where indicated

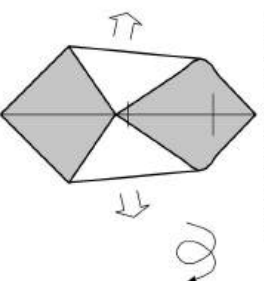

5

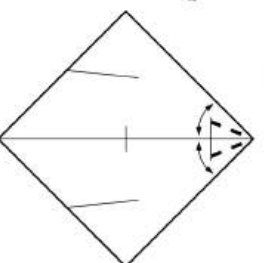

6

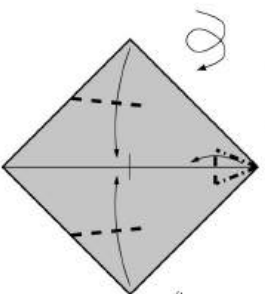

7
piega solo dove indicato
fold only where indicated

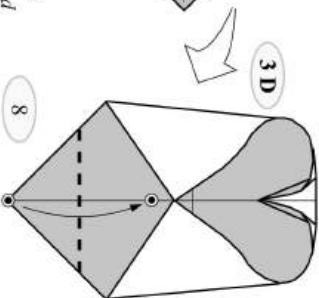

8

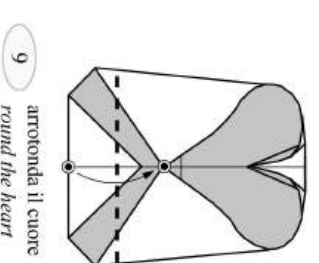

9
arrotonda il cuore
round the heart

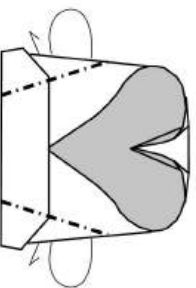

10
così il modello sta in piedi
in this way the model is standing

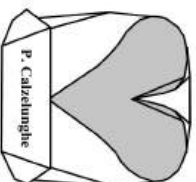

11
scrivi il nome
write the name



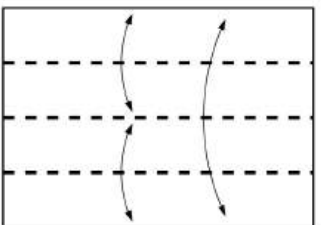

1
A4, cartoncino inumidito
A4, heavy paper, wet folded

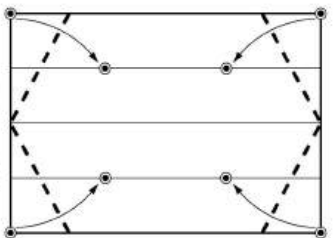

2
30°
30°

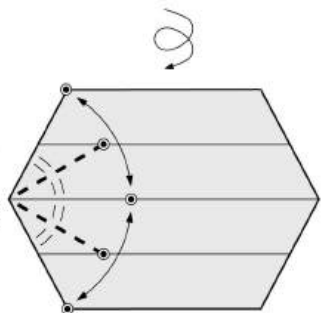

3
60°
60°

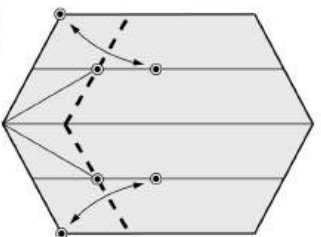

4

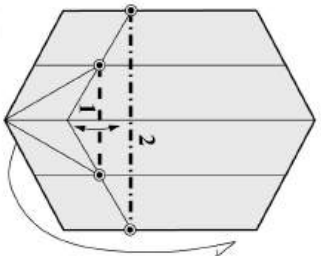

5

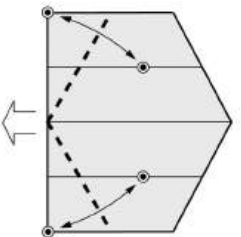

6

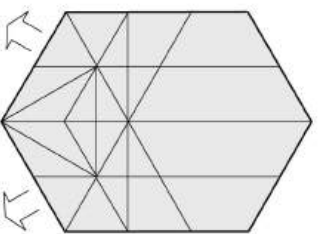

7

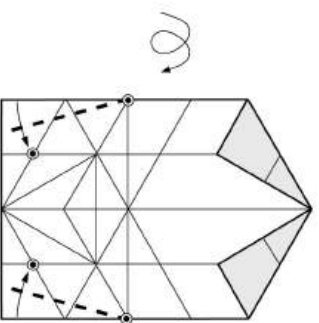

8

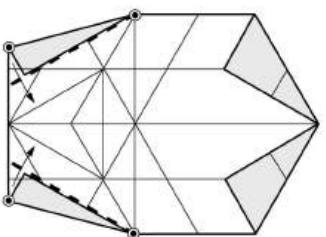

9



monte — mountain
 valle valley

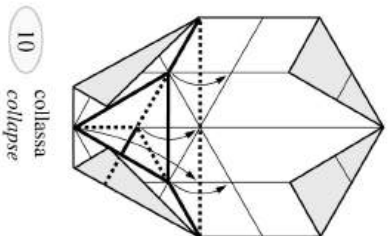

10
 collassa
 collapse

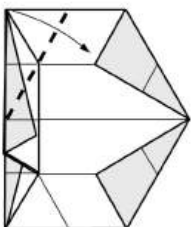

11

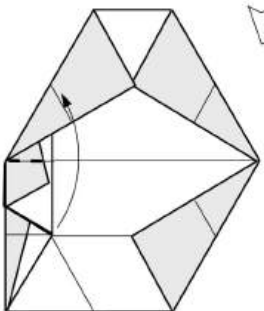

12

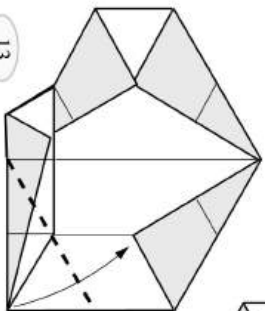

13

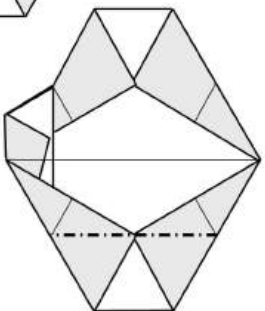

14
 rovesciata interna
 inside reverse fold

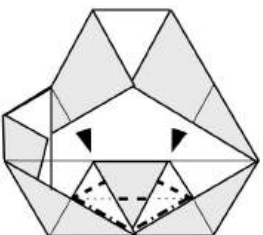

15
 rovesciata interna
 inside reverse fold

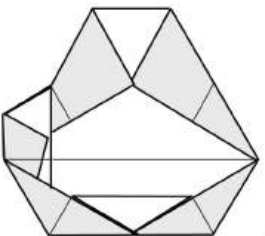

16

14-15

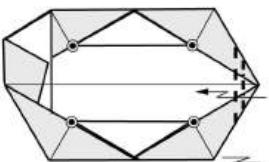

17

nota i punti di riferimento
 note the reference points

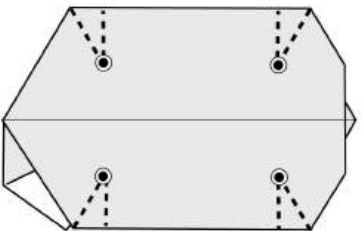

18

prepiega
 precrease



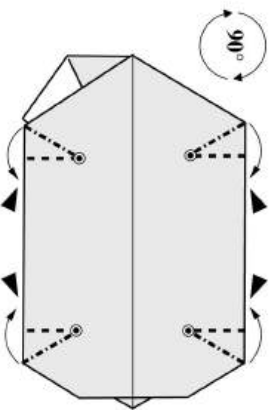

19 crimp sinkato: apri, schiaccia all'interno, richiudi
crimp – sink: open, push inside, close

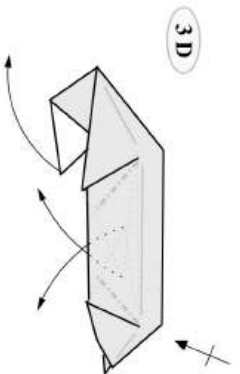

20 abbassa zampe e testa
extract legs and head

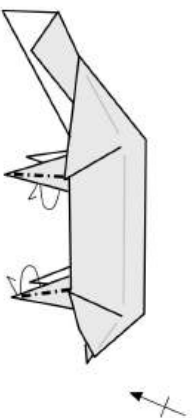

21

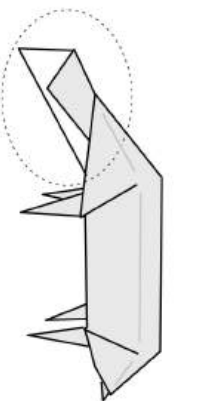

22

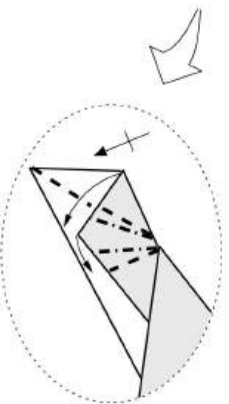

23 modella muso e orecchie
model muzzle and ears

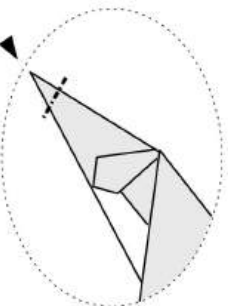

24 rovesciata interna
inside reverse fold

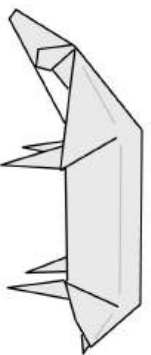

25



Cagnolino
Little dog

RG, 2008
difficoltà 1 2 3 4 5

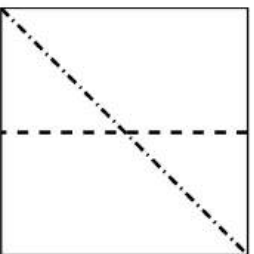

1
prepiega
precrease

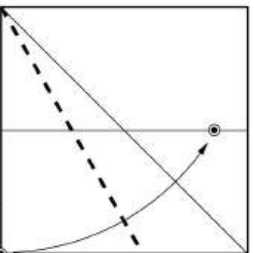

2
cerchiamo un terzo
looking for one third

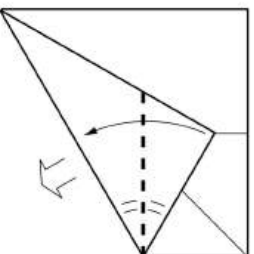

3

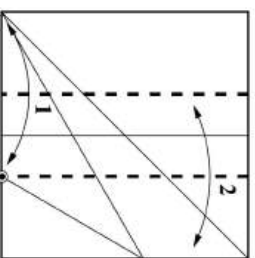

4

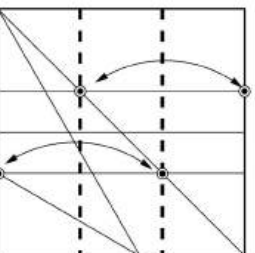

5

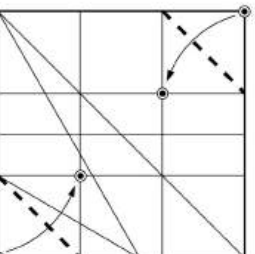

6

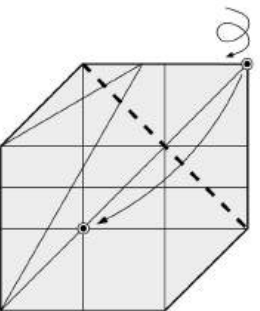

7

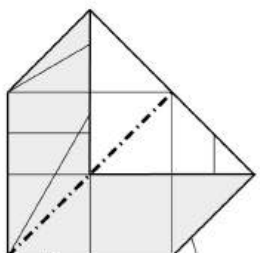

8

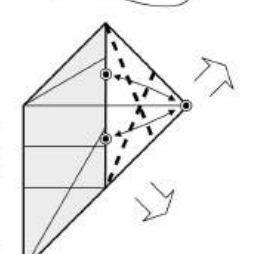

9

riapri al passo 7
reopen to step 7

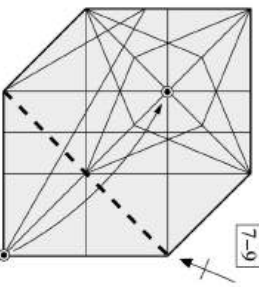

10

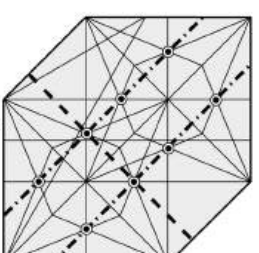

11

prepiega
precrease

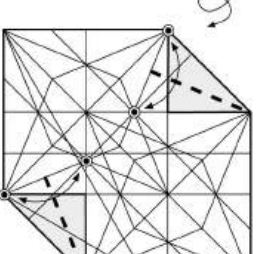

12



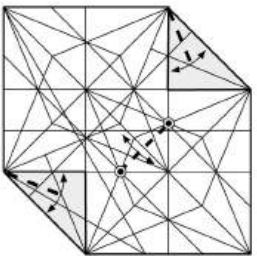

13 bisettrici
bisectors

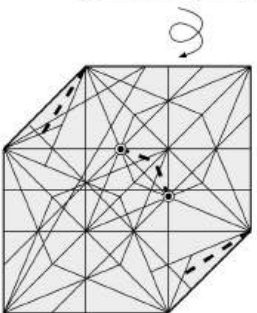

14 prepiega bisettrici
precrease bisectors

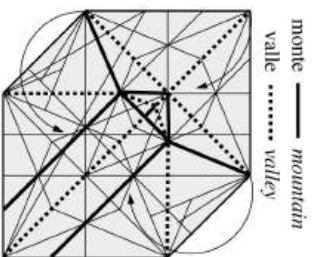

15 collassa
collapse

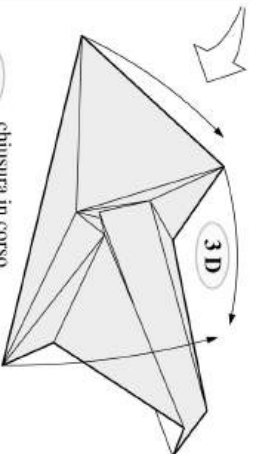

16 chiusura in corso
collapsing in progress

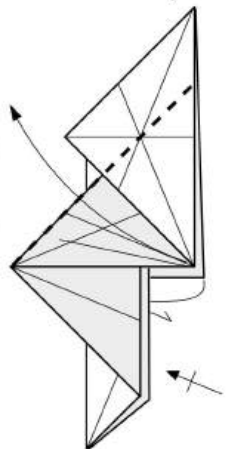

17 di nuovo piatto
flat again

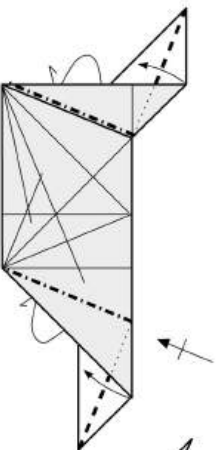

18

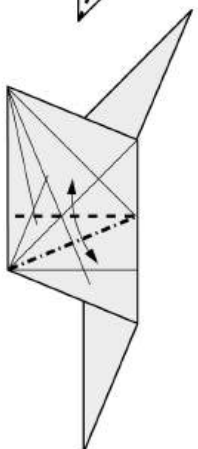

19 prepiega (il livello interno)
precrease (the internal layer)

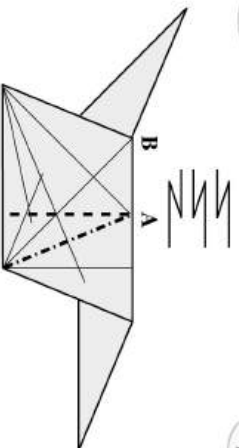

20 3 crimp (quello interno blocca il modello in A)
3 crimps (the internal one locks the model in A)

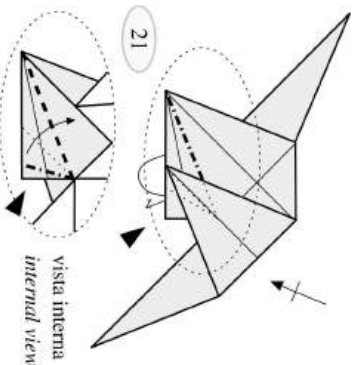

21

opzionale: puoi bloccare anche in B riarrangiando gli strati interni in modo da realizzare un crimp, come in A optional: you can lock also in B by rearranging the inner layers in order to obtain a crimp, like you did in A



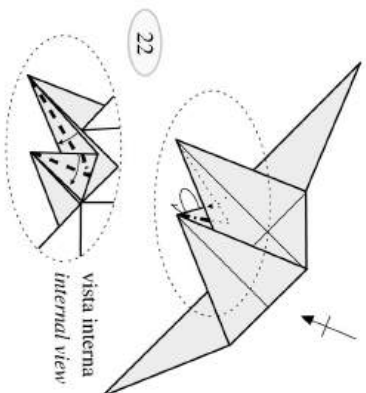

22

vista interna
internal view

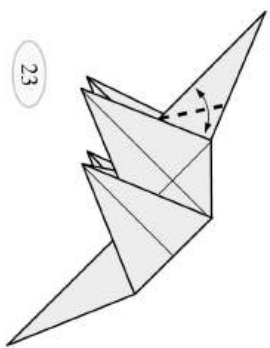

23

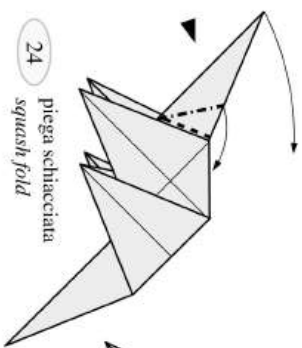

24

piega schiacciata
squash fold

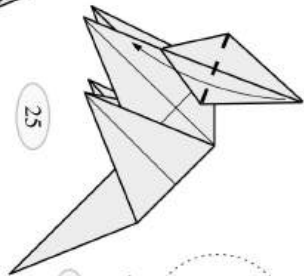

25

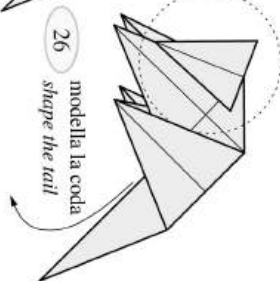

26

modella la coda
shape the tail

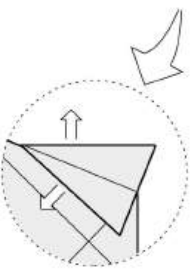

27

estrail carta
extract some paper

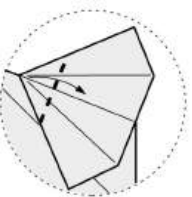

28

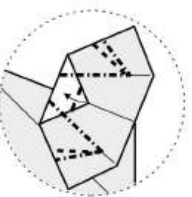

29

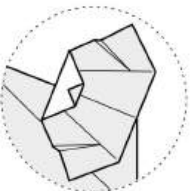

30

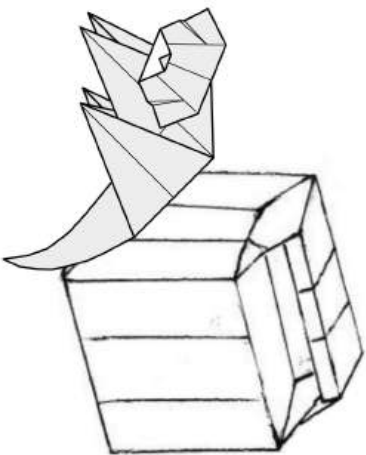
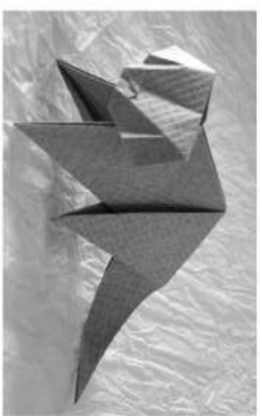

dedicato ad Elena, che ama i cani

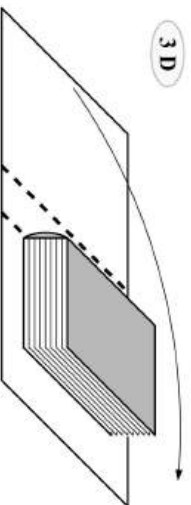

1

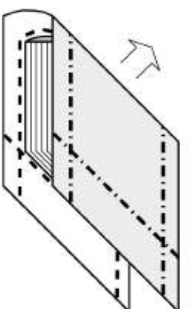

2

riporta sulla carta le dimensioni del libro
mark on the paper the sizes of the book

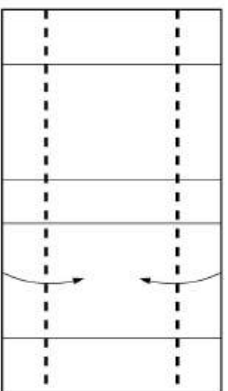

3

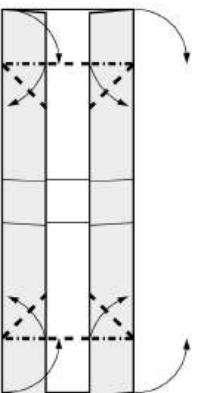

4

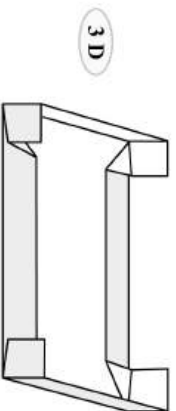

3D

5

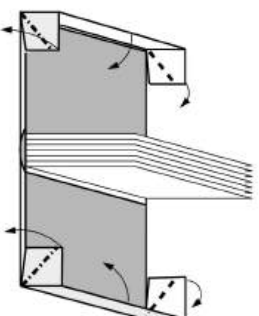

6

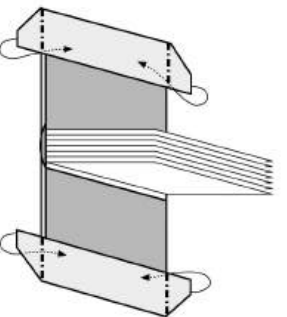

7

inserirsi nelle tasche
insert in the pockets

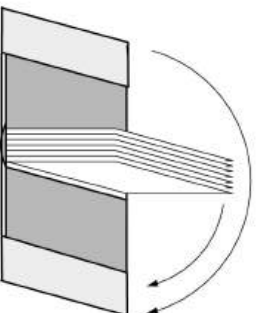

8

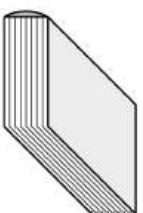

9



Nike – scatola con chiusura
Nike – locked box

RG, giugno 2012
difficoltà 1 2 3 4 5

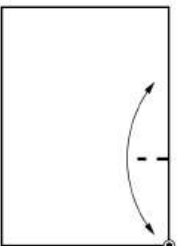

1 marca a circa un terzo
pinch at about one third

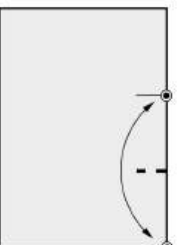

2 porta l'angolo sull'ultimo
punto trovato
bring the corner to the last pinch

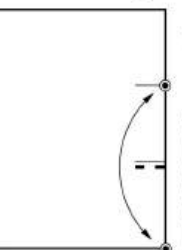

3 porta l'angolo sull'ultimo
punto trovato
bring the corner to the last pinch

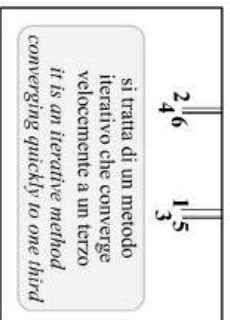

si tratta di un metodo
iterativo che converge
velocemente a un terzo
it is an iterative method
converging quickly to one third

4 ripeti i passi 2 e 3 fino a che i punti
non si spostano: hai trovato un terzo
repeat steps 2 and 3 until convergence

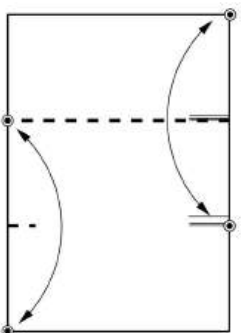

5

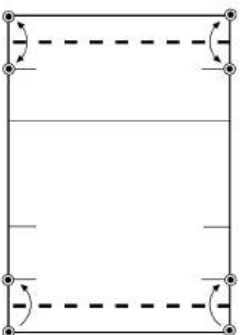
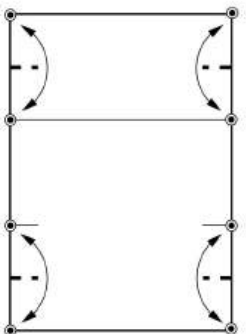

6

7

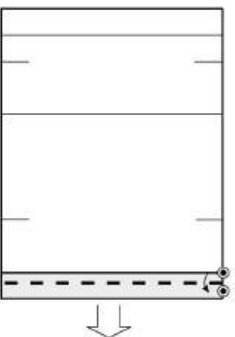

8

9

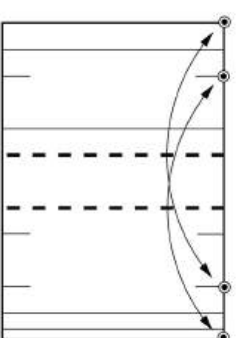

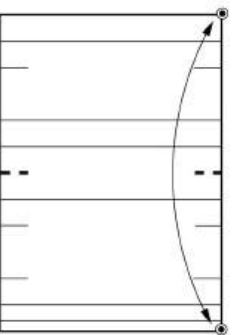

10

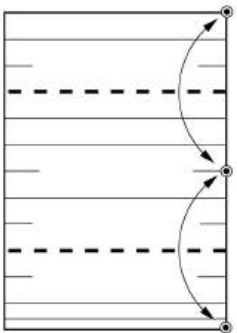

11

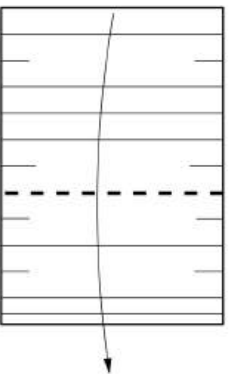

12

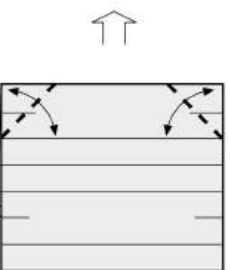

13

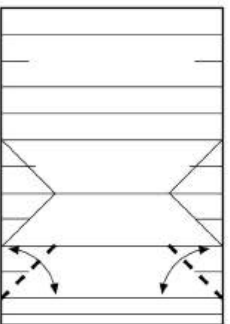

14

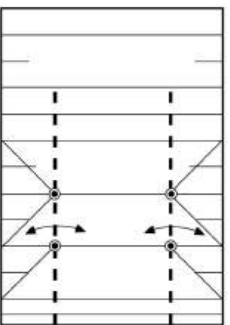

15

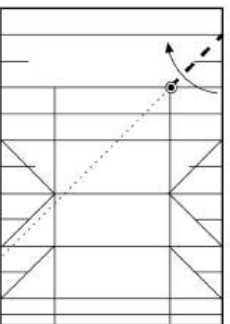

16

marca solo dove indicato
crease only where indicated

17

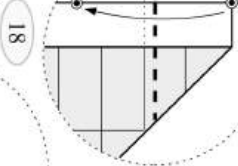
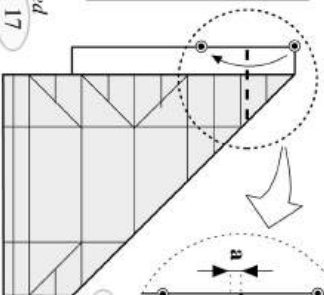

18

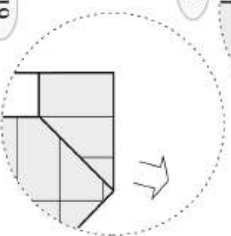

19

la distanza "a" (indicativamente 2-5 mm) dipende dallo spessore della carta e serve a facilitare la chiusura del copertino
distance "a" (indicatively 2-5 mm) depends on paper thickness and is needed to make it easier to close the lid



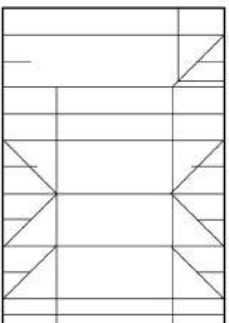

16-19

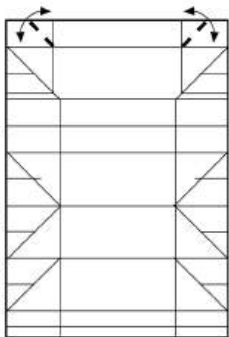

21
piegatura finita. WEW!
end of precreasing. WEW!

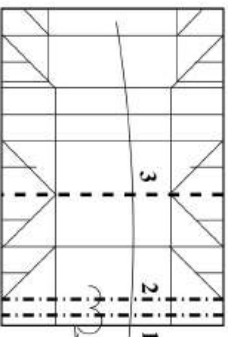

22

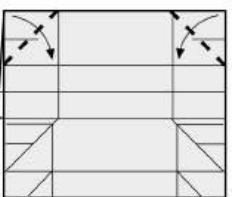

23

3 D

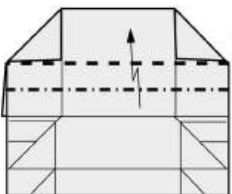

24

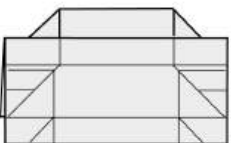

25

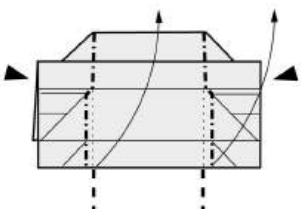

26

solo il livello sotto non si alza
only the lower layer does not lift

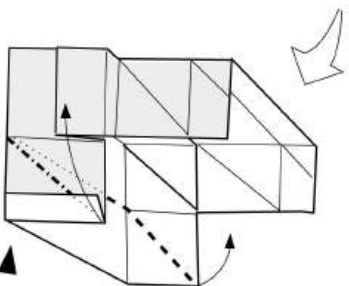

27

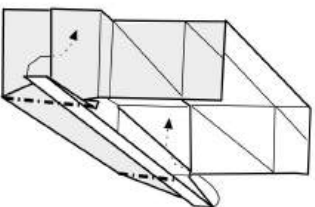

28

infilia la punta sotto la tasca
tuck the point under the pocket

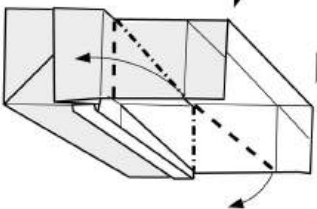

29

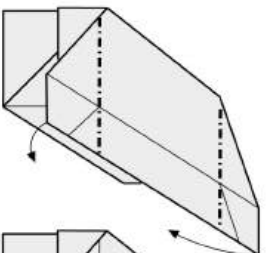

30

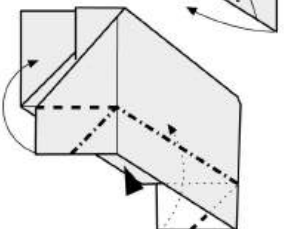

31

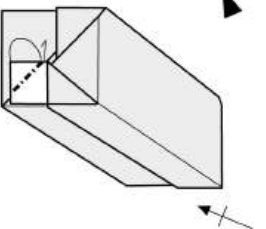

32
blocca
lock

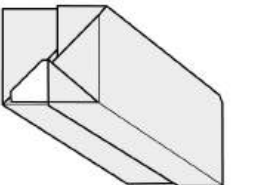

33
Nike

partendo da rettangoli di proporzioni diverse si possono ottenere una intera famiglia di scatole *starting from rectangles having different proportions, you can get a whole family of boxes*

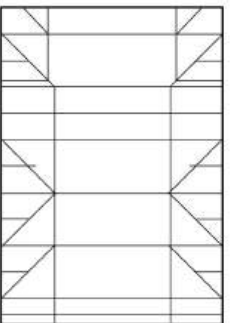

A4 orizzontale
A4 landscape

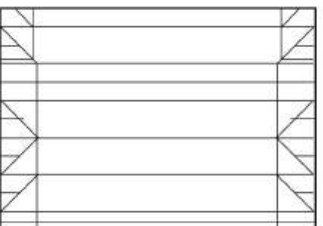

A4 verticale
A4 portrait

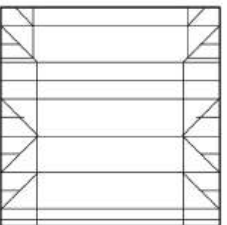

quadrato
square

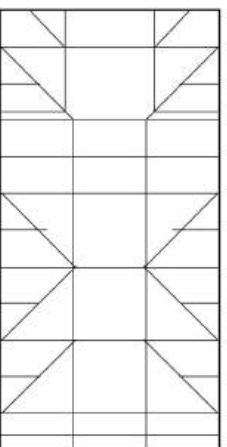

un rettangolo 2x1 (mezzo quadrato) genera una scatola cubica
a rectangle 2x1 (half a square) leads to a cubic box



Scatola Coroncina
Little crown bowl

RG, giugno 2012
difficoltà 1 2 3 4 5

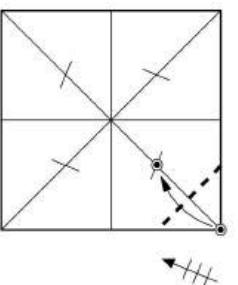
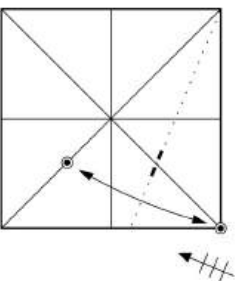
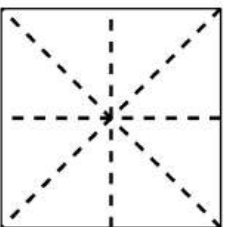

1 colore sotto, prepiega
color down, precrease

2

3

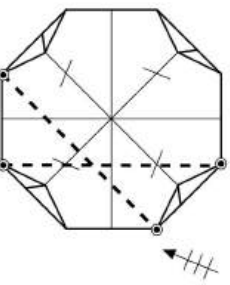
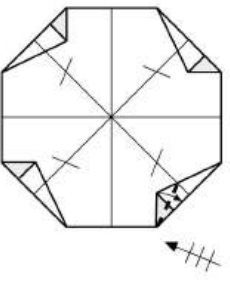
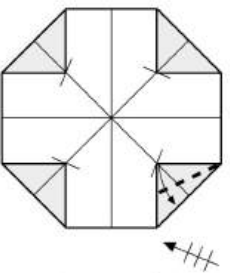

4 ottagono regolare
regular octagon

5

6

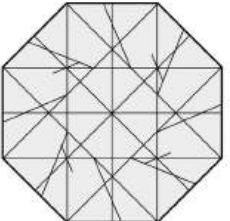
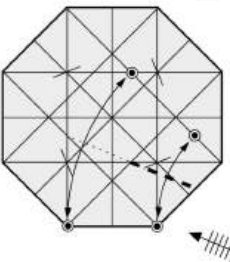
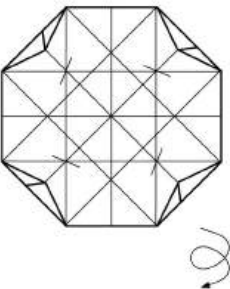

7

8

9

monte
mountain
valle
valley

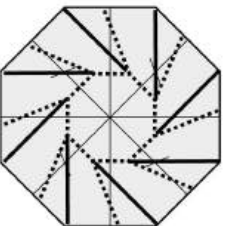

10



3D

bloccaggio
lock

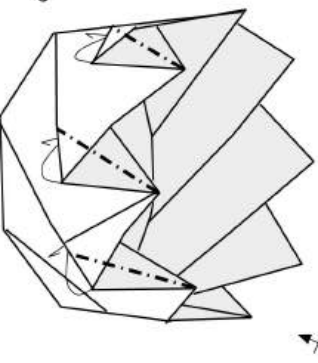

11



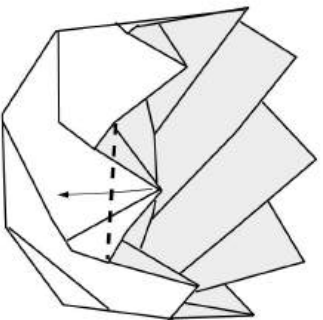

12 la prima aletta non può andare a posto perché è bloccata dall'ultima
the first flap cannot go in place because it is blocked by the last one

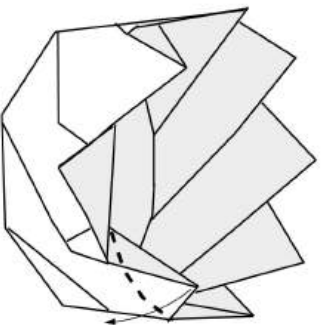

13 seconda aletta a posto
second flap ok

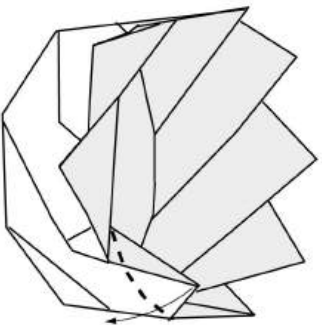

14 terza aletta a posto
third flap ok

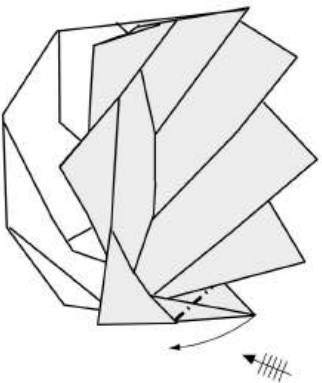

15 continua fino alla fine
continue until the end

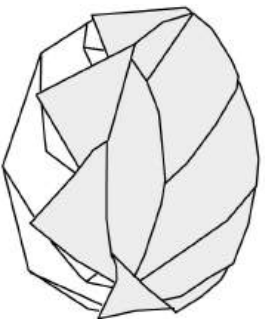

16 ora la prima aletta può andare a posto
now also the first flap can go in place



Scatola con 8 cuori
8-hearted box

RG, primavera 2012
difficoltà 1 2 3 4 5

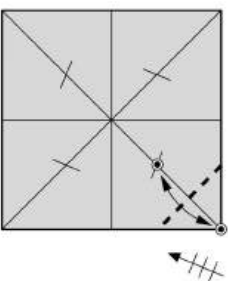
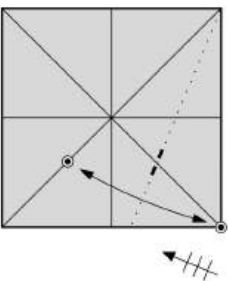
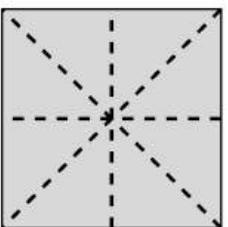

1 rosso sopra, prepiega
red up, precrease

2

3

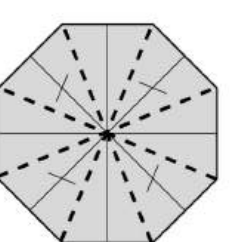
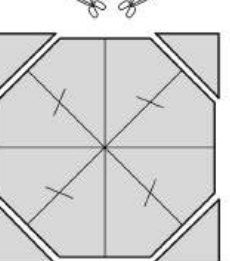
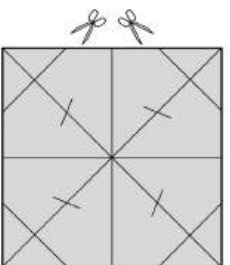

4 taglia gli angoli
cut the corners

5 ottagono regolare
regular octagon

6 piega e riapri
precrease

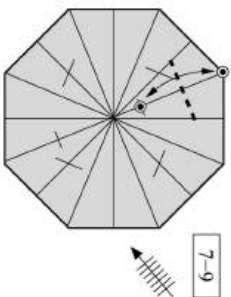
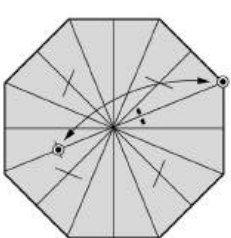
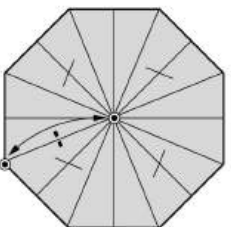

7

8

9

7-9

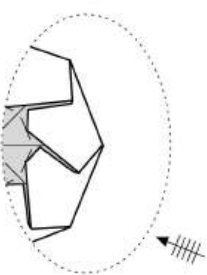
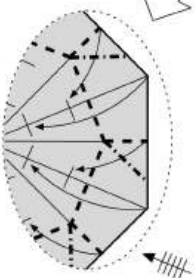
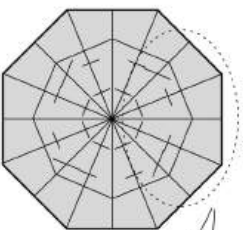

10

11

12



13 pieghe schiacciate
squash folds

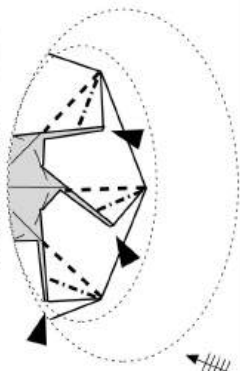

14

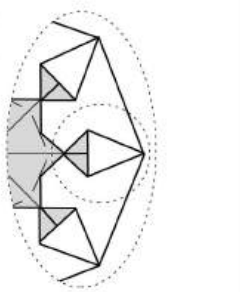

15-17

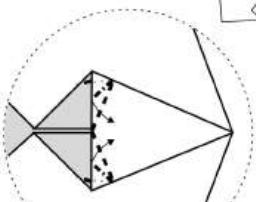

15 swivel
swivel folds

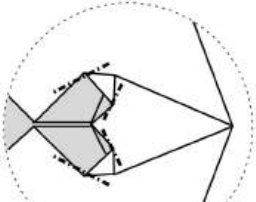

16 arrotonda
make it round

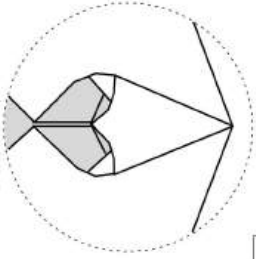

17 cuore finito
heart done

18-20

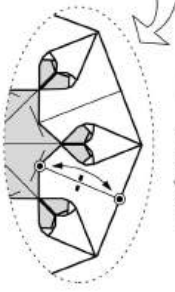

18

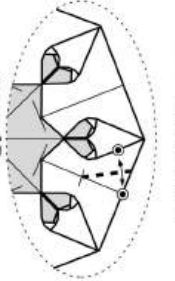

19 mossa 3D
3D move

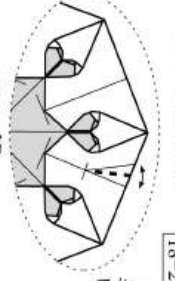

20 mossa 3D
3D move

3D

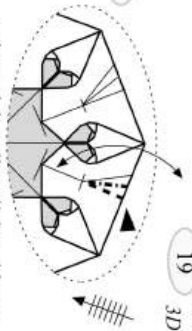

20 crimp sink: solleva l'aletta bianca,
schiaccia dove indicato e richiudi
crimp sink: raise the white flap,
push inside where indicated and close

21

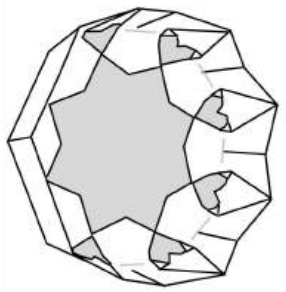

utile se si sopravvive alla crisi del settimo anno...
useful if you survive the 7-years crisis...



Segnalibro quadrifoglio
Four leaf clover bookmark

RG, giugno 2012
difficoltà 1 2 3 4 5

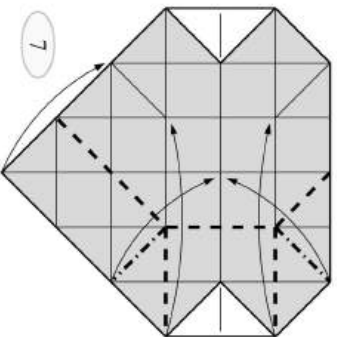
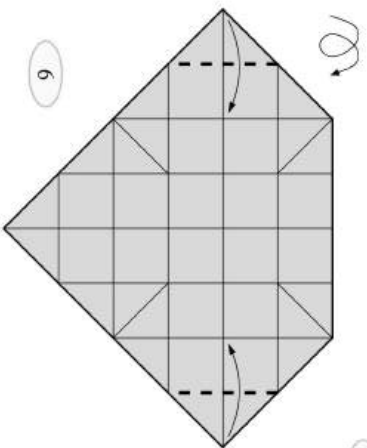
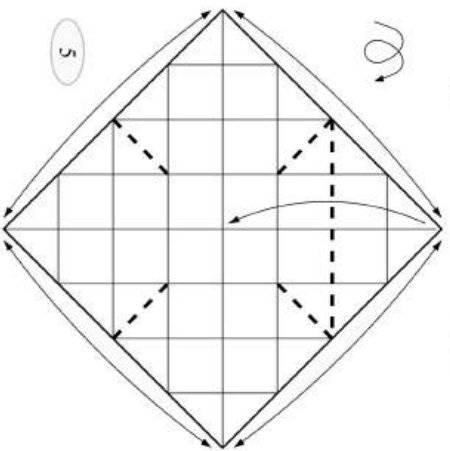
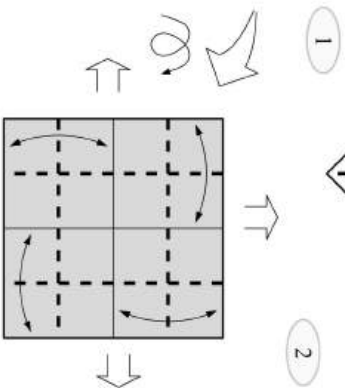
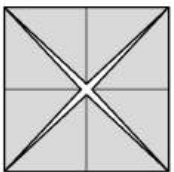
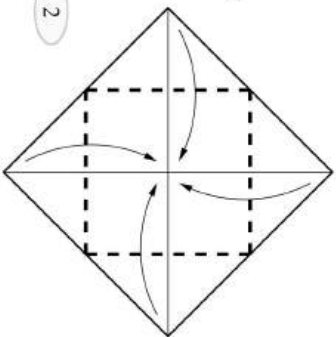
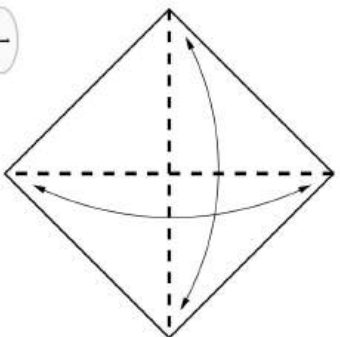

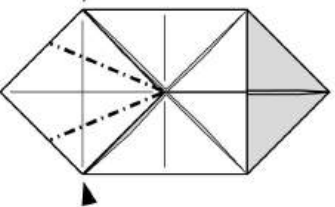
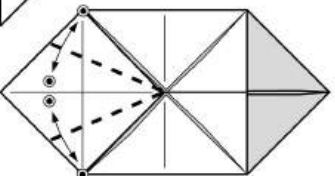
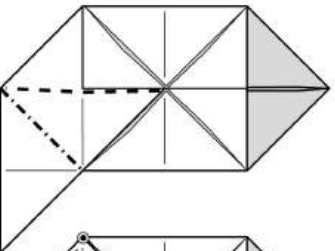
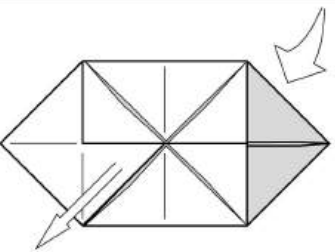
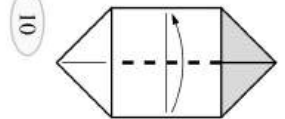
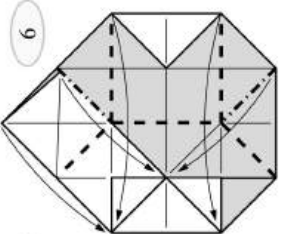
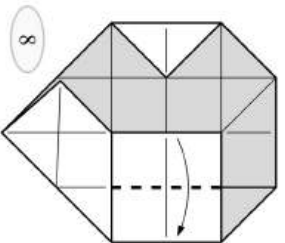

11 estrai carta
extract some paper

12 piega schiacciata
squash fold

13

14

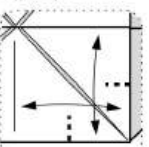

16 petalo
petal

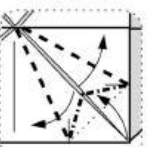

17

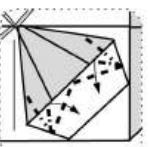

18

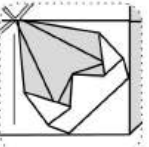

19

16-19

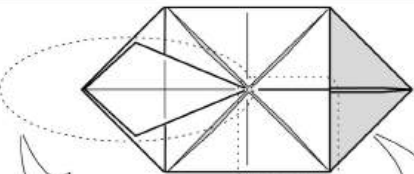

15

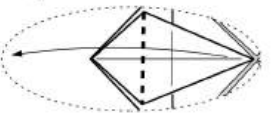

20 gambo
stem

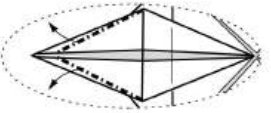

21 estrai
carta
*extract
paper*

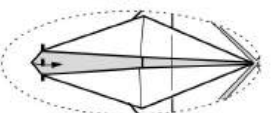

22

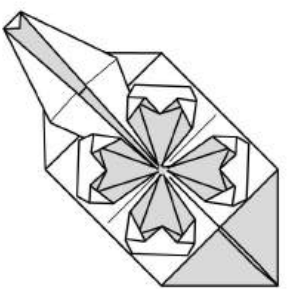

dedicato a Monica,
che spera in un po' di fortuna



DNA bicolore – variazione del DNA di Thoki Yenn
 Bicolor DNA – variation of DNA by Thoki Yenn

RG, 2011
 difficoltà 1 2 3 4 5

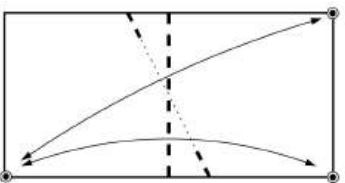

1 rettangolo 2x1
 2x1 rectangle

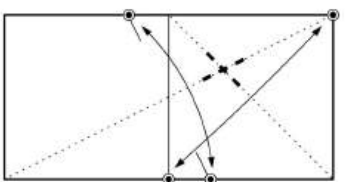

2

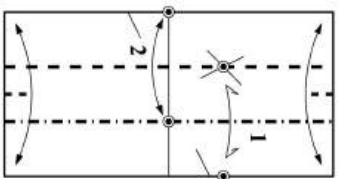

3

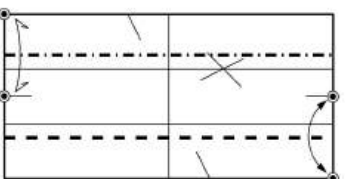

4

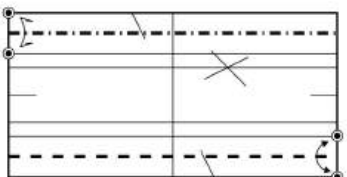

5

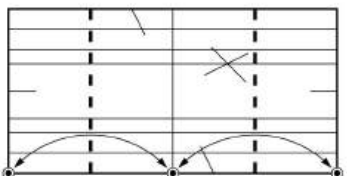

6

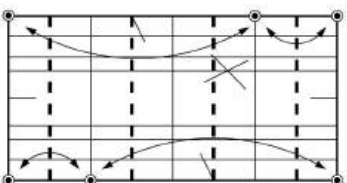

7

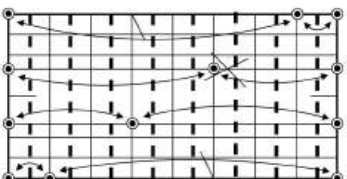

8

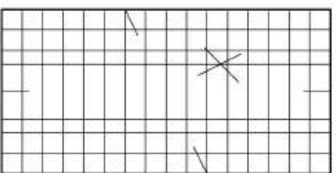

9

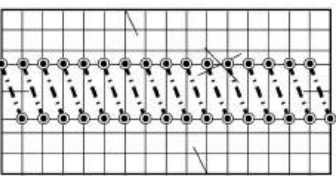

10

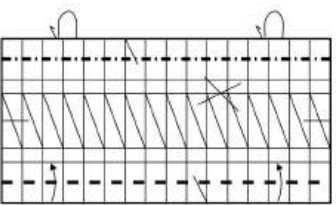

11

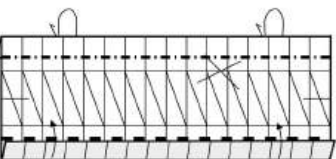

12



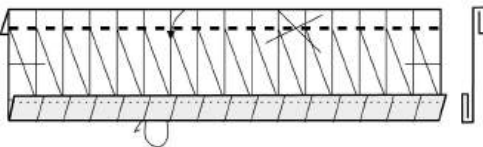

3 D

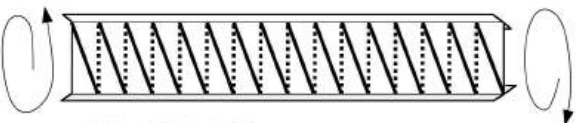
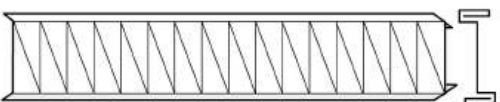

monte
mountain

valle
valley

questo l'ho già visto!
I already saw this!



13 pieghe perpendicolari
perpendicular folds

14 prepiegatura finita
stop precreasing

15

ruota delicatamente
assecondando le pieghe,
il DNA si chiude da solo
*rotate gently without
causing about the creases,
DNA will close by itself*

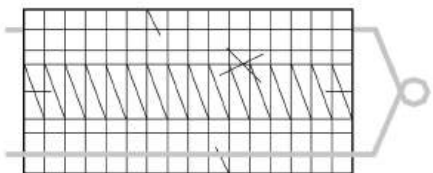
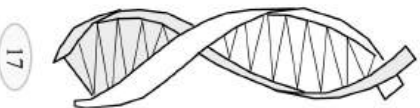

16 continua...
continue...

17

volendo fare dei gioielli, conviene
inserire un filo metallico al passo 11
*if you want make some jewelry,
insert a metallic wire at step 11*



Papavero

Poppy

usa carta velina: viene mostrata carta bicolore solo per chiarezza
 use tissue paper: bicolor paper shown only for clarity purposes

RG, estate 2009
 difficoltà 1 2 3 4 5

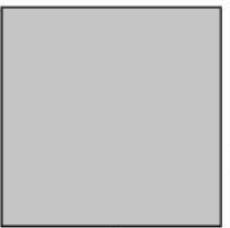

petali, rossi petals, red



corolla, nera
 corolla, black



gambo, verde stem, green

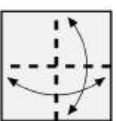

1 corolla

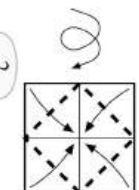

2

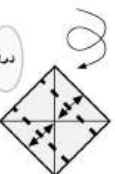

3



4



5

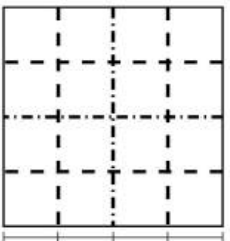

1 petali, prepiega
 petals, precrease

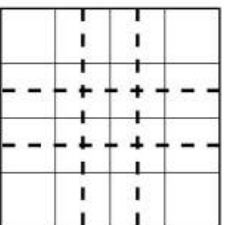

2 prepiega
 precrease

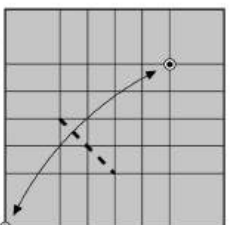

3

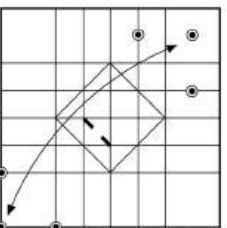

4

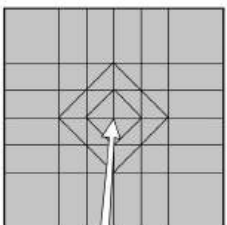

5 appoggia la corolla al centro
 put the corolla in the center

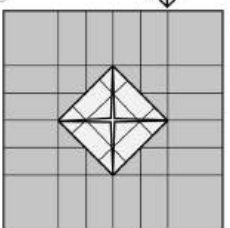

6

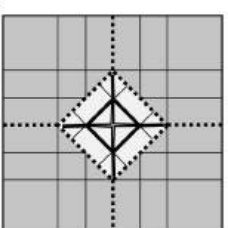

7

collassa, bloccando la corolla
 collapse, this will lock the corolla

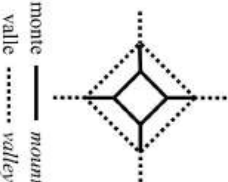

monte — mountain
 valle valley

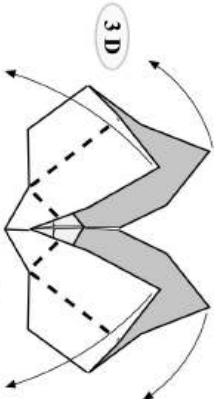

3 D

8

apri i petali
 open the petals



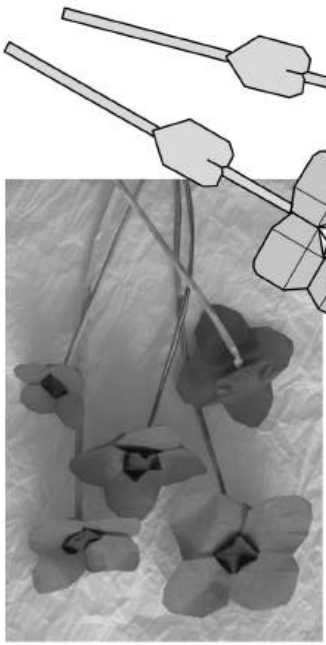
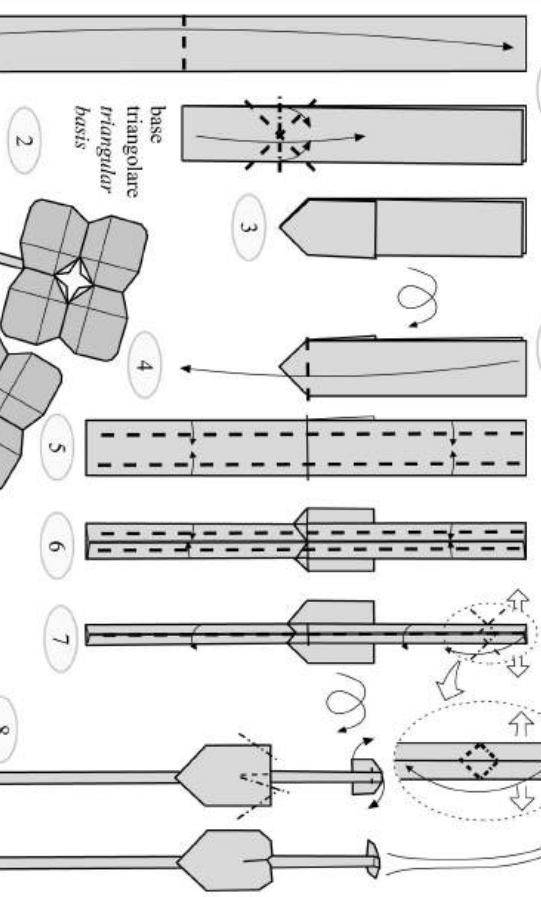
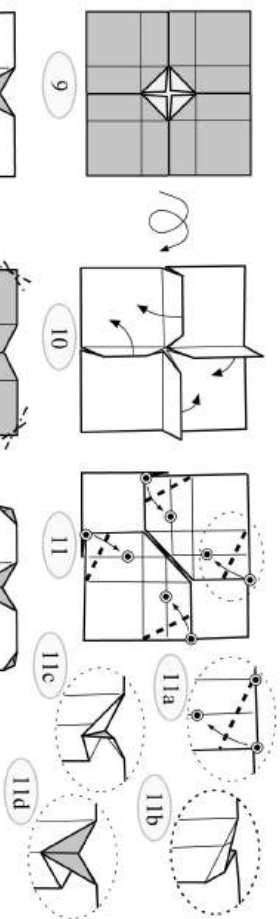

9
incastra
insert



Nontiscordarime

Forget-me-not

RG, autunno 2009

difficoltà 1 2 3 4 5

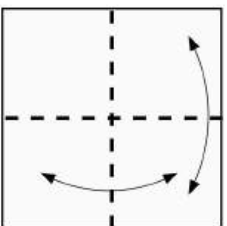

1 giallo su yellow up

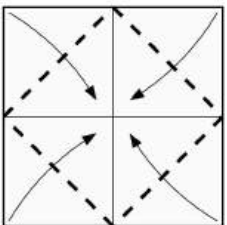

2

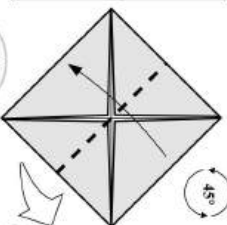

3

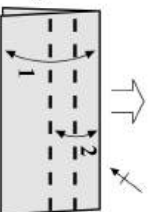

4

piega solo lo strato davanti upper layer only

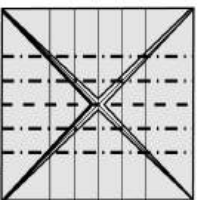

5 ripeti 3-4 repeat 3-4

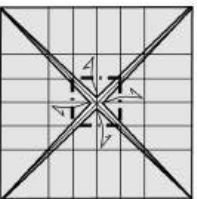

6

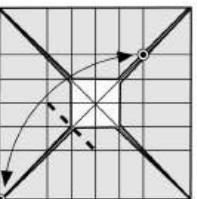

7

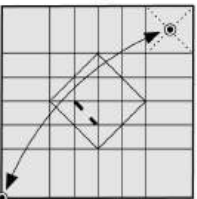

8

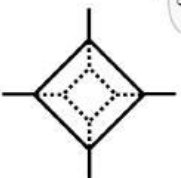

monte — mountain
valle valley

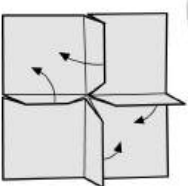

10

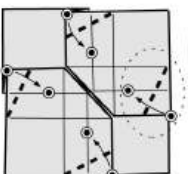

11

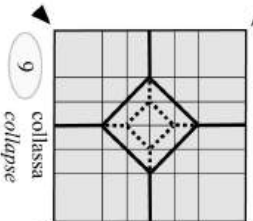

9

collassa collapse

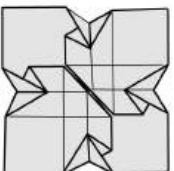

12

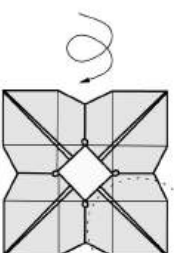

13

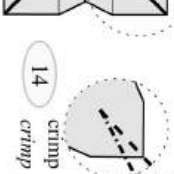

14

crimp crimp

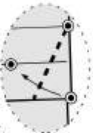

11a

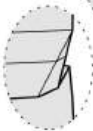

11b



11c

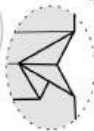

11d

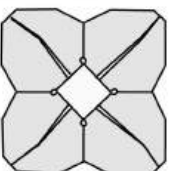
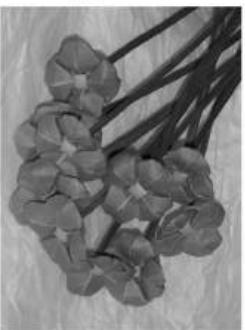

Nontiscordarime
Forget-me-not

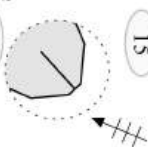

15

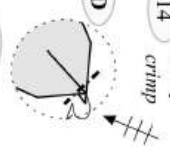

16

puoi usare lo stesso gambo del papaverino
you can use the same stem of the poppy



Fiore ... con la stella Flower ... with a star

variante esagonale del fiore ... con il cuore di Maria Grazia Zordan
hexagonal variation of "fiore ... con il cuore" by Maria Grazia Zordan
 usa un A4 di carta da fotocopie colorata, ritagliando un esagono
 use an A4 of colored copy paper, obtaining an hexagon

RG, ottobre 2001
 difficoltà 1 2 3 4 5

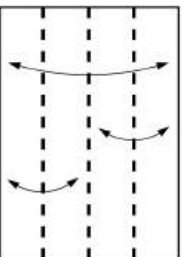

1

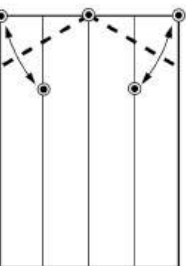

2
 piega a 60°
 fold at 60°

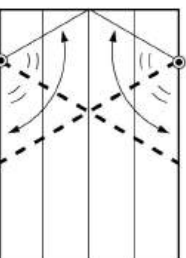

3
 bisettrici
 bisectors

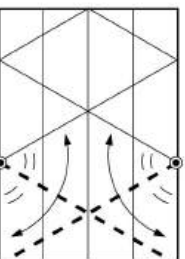

4
 bisettrici
 bisectors

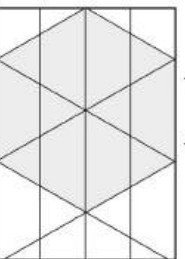

5

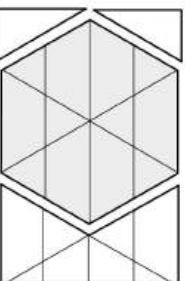

6
 esagono regolare
 regular hexagon

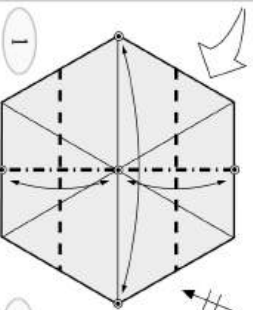

1

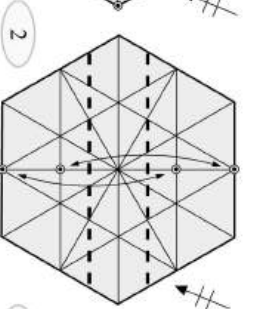

2

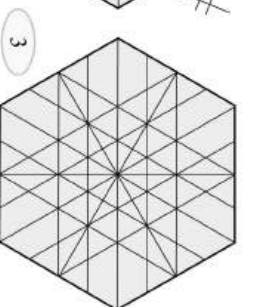

3

monte
 mountain
 valle
 valley

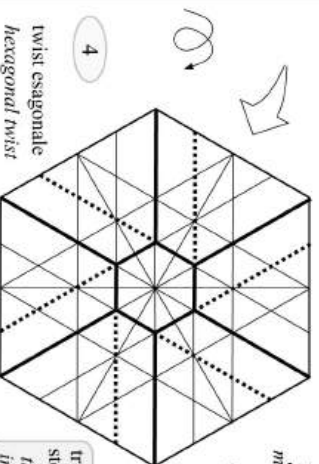

twist esagonale
 hexagonal twist

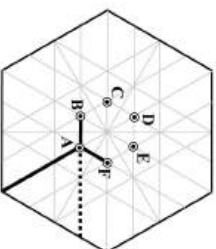

trucco: piega localmente come indicato in A, poi fai lo stesso in B, poi in C... alla fine il twist si forma da solo
 trick: fold locally as indicated in A, then do the same in B, then in C... at the end the twist will form for free



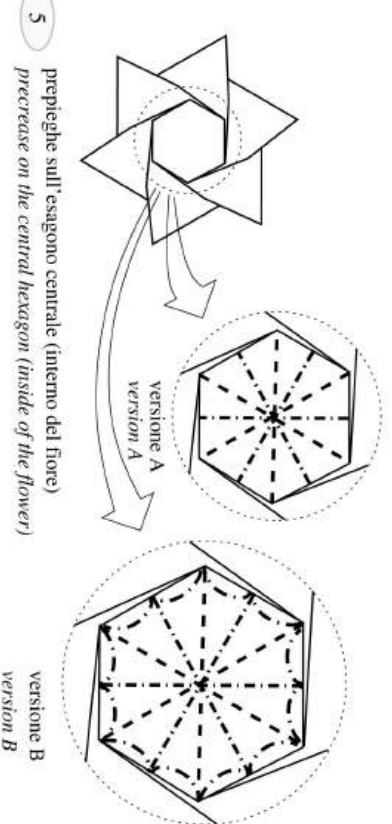

- 5 **prepieghe sull'esagono centrale (interno del fiore)**
precrease on the central hexagon (inside of the flower)

solo per la versione A *version A only*

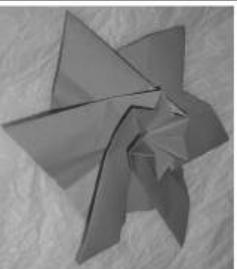

- 5a **alza le alette centrali**
raise the central flaps



- 5b **appiattiscile**
make them flat



- 5c **fai una curvatura morbida**
make a soft curve

questo movimento semplifica la chiusura al passo 13, preparando in anticipo la spirale che si formerà all'interno del fiore
this movement simplifies the closure at step 13, preparing in advance the spiral that will form in the inside of the flower

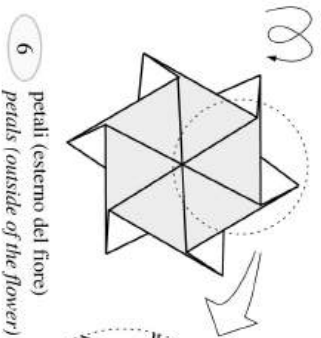

- 6 **petali (esterno del fiore)**
petals (outside of the flower)

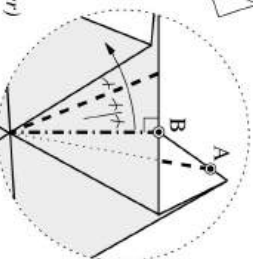

- 7 **il punto A non è sulla cima del petalo**
point A is not on the top of the petal

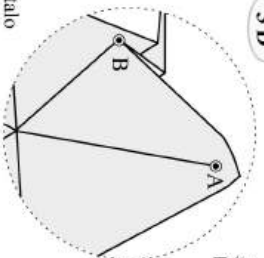

- 8 **le punte dei petali non sono piatte**
the top of the petals are not flat

3D

7-8



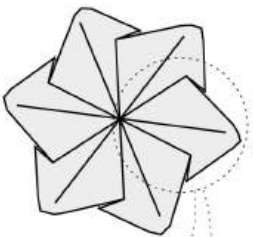

9

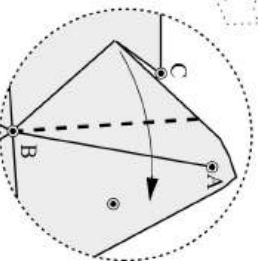

10
 piega a destra: il punto C
 deve arrivare sulla linea AB
*fold to the right: point C
 must reach the line AB*

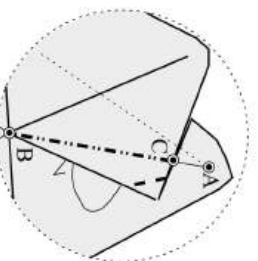

11
 inserisci l'ala nella tasca con
 una piega a monte; siccome la tasca
 non è molto profonda occorre
 fare una seconda piega (a valle)
*insert the flap into the pocket
 with a mountain fold;
 as the pocket is not so deep
 a second (valley) crease is needed*

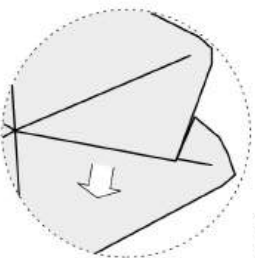

10-12

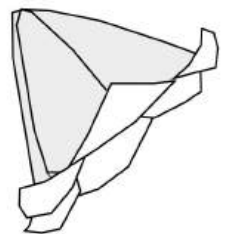
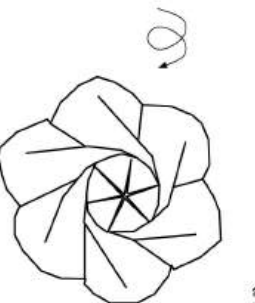

12
 questo è l'esterno del fiore;
 riapri al passo 11, poi
 ripeti su ogni petalo
*this is the external part of
 the flower: reopen to step 11,
 then repeat on the other petals*

13
 per chiudere il fiore devi richiudere le ali esterne e
 contemporaneamente verificare che nel centro (all'interno)
 si formi correttamente la stella esagonale
*to close the flower you must close again the external
 flaps and at the same time verify that in the center
 (in the inside) the hexagonal star will form*

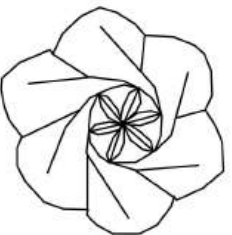
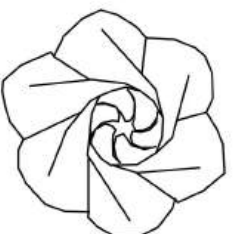

14
 versione A: fai ruotare i singoli raggi della stella
 in senso orario (questo facilita la chiusura);
 la stella al centro si forma da sola
*version A: push every ray of the star
 clockwise (this makes the closure easier);
 the star in the center will form for free*

15
 versione B: premi da
 sopra in modo da ritare le
 pieghe a monte del passo 5
*version B: push from above
 in order to redo the
 mountain folds of step 5*



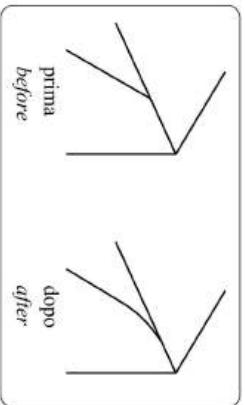

ogni petalo ha una punta che va arrotondata:
nel farlo, una delle pieghe che formano
il crimp diventa curva (un asintoto)
*every petal has a point that has to be rounded:
by doing so, one of the creases that form
the crimp becomes curve (an asymptote)*



16
premi con l'unghia
proprio sotto la punta
*push with the nail
just below the point*



17
passa l'unghia dell'indice avanti e indietro da
sotto contro il polpastrello del pollice da sopra
*move the nail of the index from below back
and forth against the thumb from above*



18
punte arrotondate
rounded points

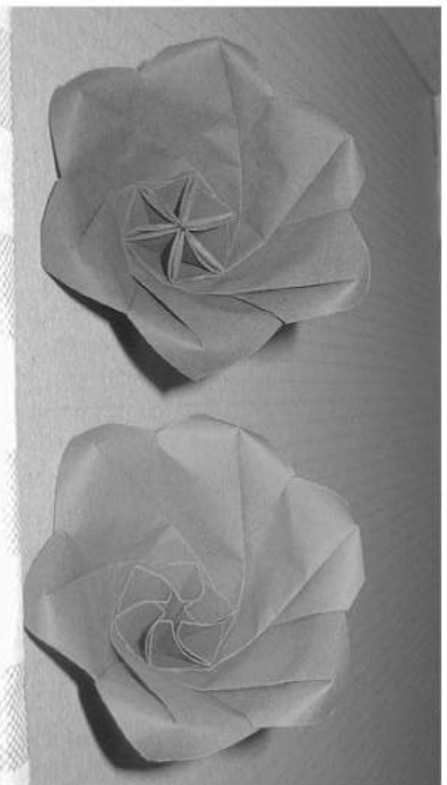

dedicato a Nicoletta, che più di ogni altro ha apprezzato questo fiore

Fiore d'aprile
April flower

RG, aprile 2008
difficoltà 1 2 3 4 5

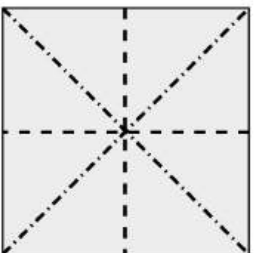

1
piegata
precrease

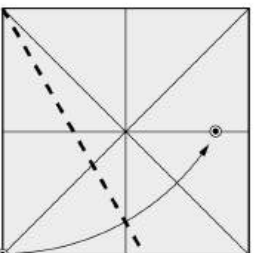

2
cerchiamo un terzo
looking for one third

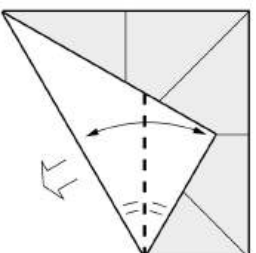

3

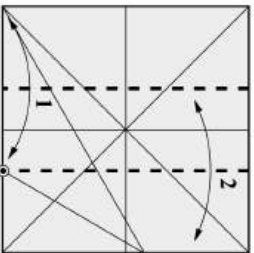

4

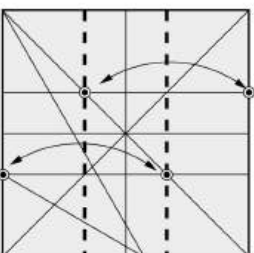

5

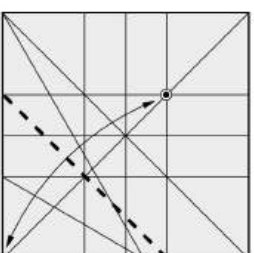

6

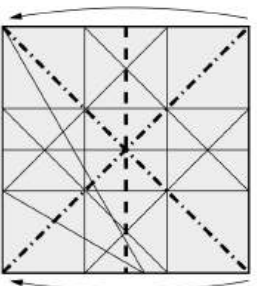

7
base triangolare
triangular base

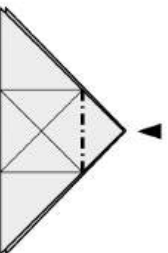

8
sink aperto
open sink

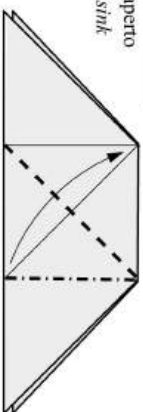

9
piega schiacciata
squash fold

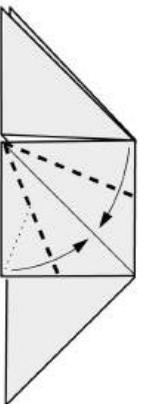

10

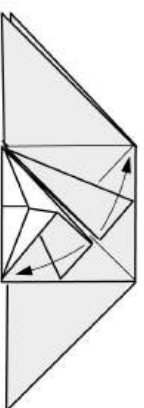

11



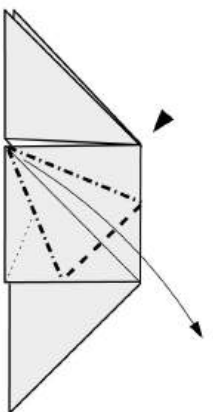

12 piega a petalo
petal fold

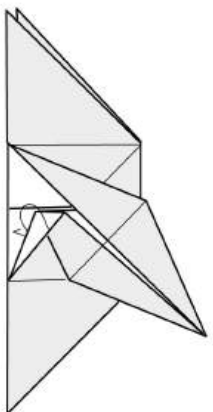

13 porta dietro l'aletta
bring the flap behind

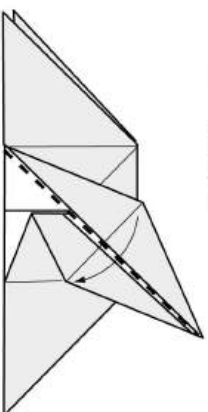

14

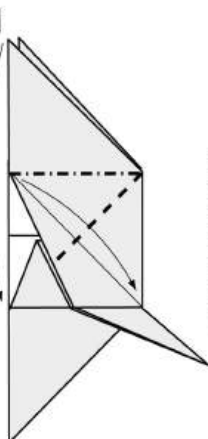

15 piega schiacciata
squash fold

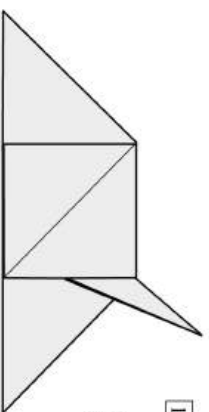

10-14

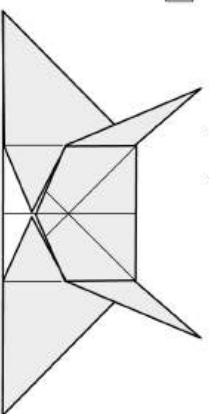

17

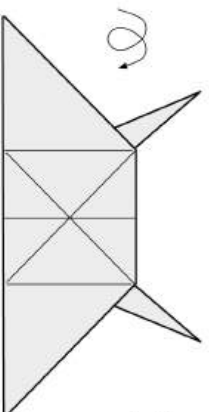

9-17

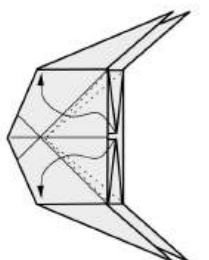

18 non serve ripetere il passo 13
no need to repeat step 13

19 rovesciate interne
inside reverse folds

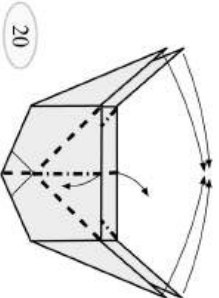

20

3D

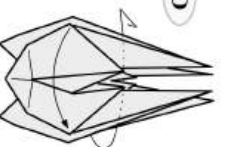

21

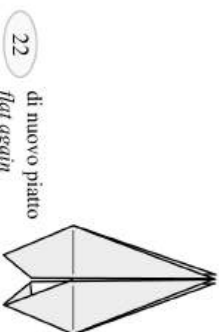

22 di nuovo piatto
flat again



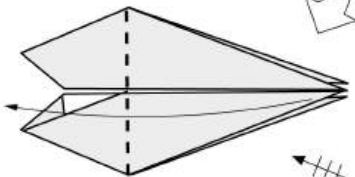

23 abbassa i 4 petali
lower the 4 petals

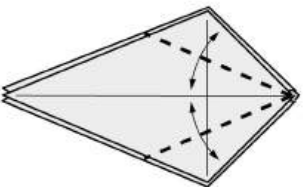

24

25 piega schiacciata
squash fold

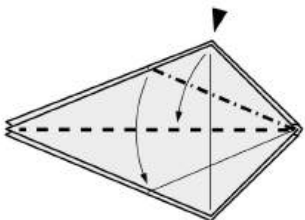

26

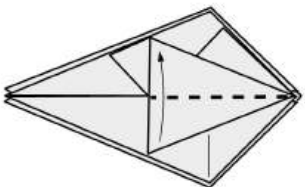

25-26

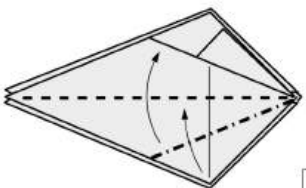

27

28

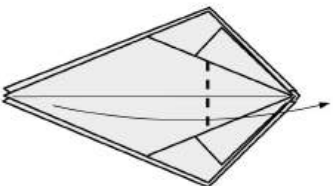

29

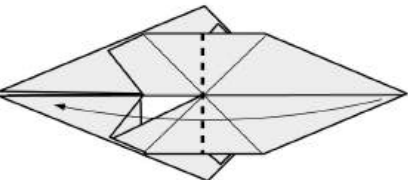

30

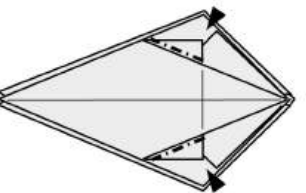

30 rovesciate interne
inside reverse folds

24-30

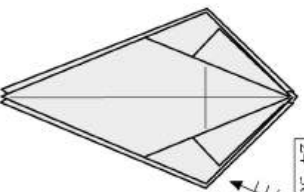

31

31 ripetit sugli altri
3 petali
repeat on the
other 3 petals

32

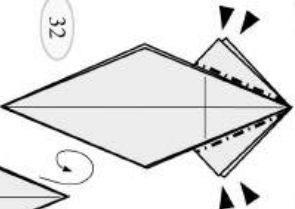

3 D

32 vista da sotto
bottom view



34

34 vista da sopra
view from above

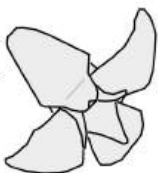

33 alza i petali, estrai carta,
arriccia e modella il fiore
raise petals, extract paper,
round and model the flower



Carrozzina

Pram

usa carta pelle elefante oppure sandwich alluminio-velina: misura consigliata 35 cm
 use either elephant hide or tissue foil sandwich; suggested size 35 cm.

difficoltà **1 2 3 4 5**

RG, autunno 2004

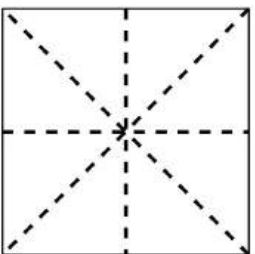

1 bianco su, pieghia white up, precrease

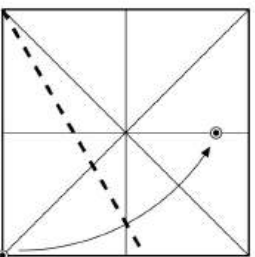

2 piega a 30° fold at 30°

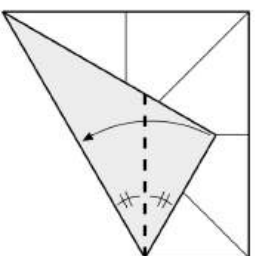

3

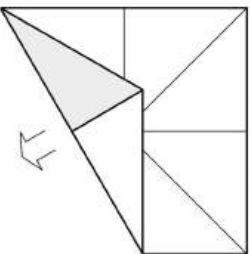

4

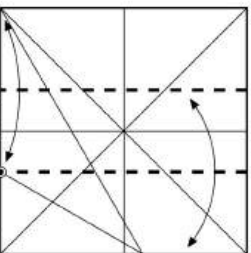

5 divisione in terzi divide in thirds

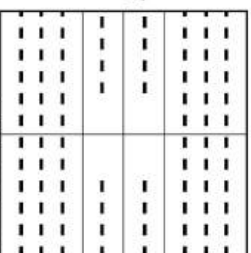

6 dividi in dodicesimi divide in 12th

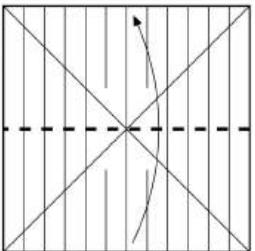

7

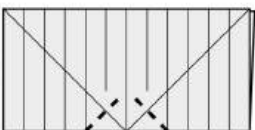

8



9

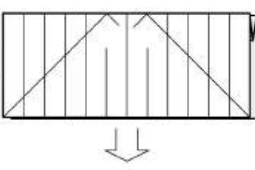

10

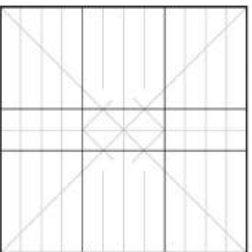

11

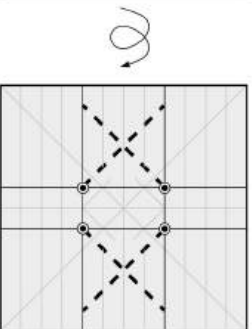

12

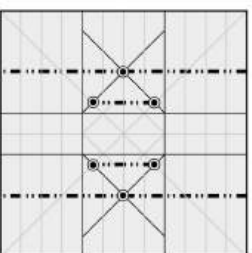

13



prova 3D per mostrare alla carta cosa dovrà fare...
just a 3D test to show the paper what it will do later...

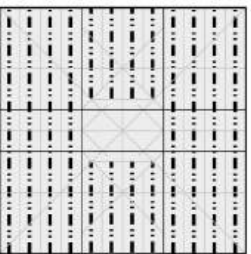

90°
 monte
 mountain
 valle
 valley

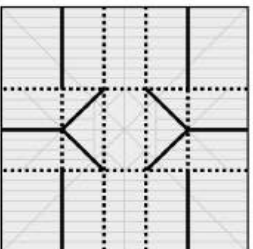

14a crease pattern

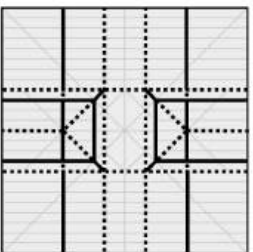

14b crease pattern

14 stesso verso del passo 6
same direction of step 6

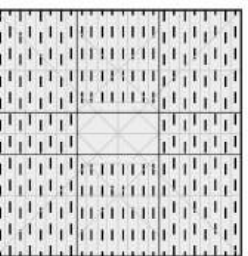
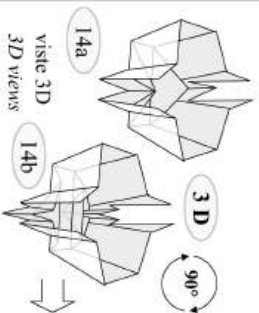

15 prepieghe a zig zag
precrease in accordion

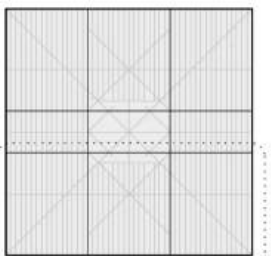

16

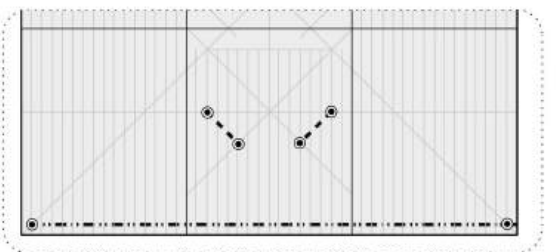

17

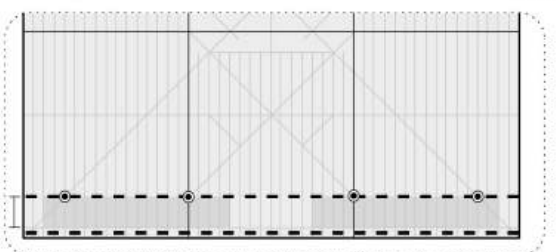

raggio / radius: $18/6,28=2,87 \rightarrow 3$

circonferenza: 18 segmenti
circumference: 18 segments

18 ogni rettangolo grigio diverrà una ruota
each grey rectangle will become a wheel

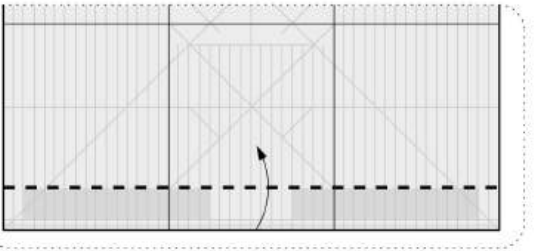

19



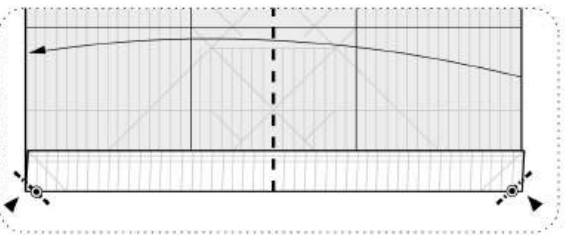

20 pieghe rovesciate a 45°
reverse folds at 45°

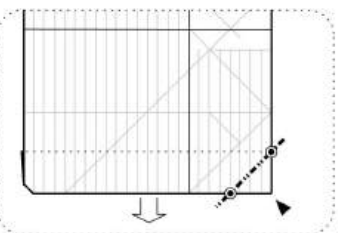

21 piega rovesciata a 45°, poi riapri tutto
then reverse fold at 45°
then reopen everything

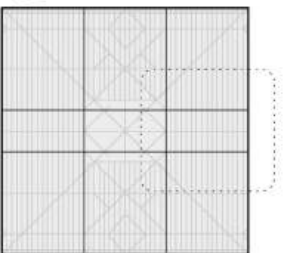

22

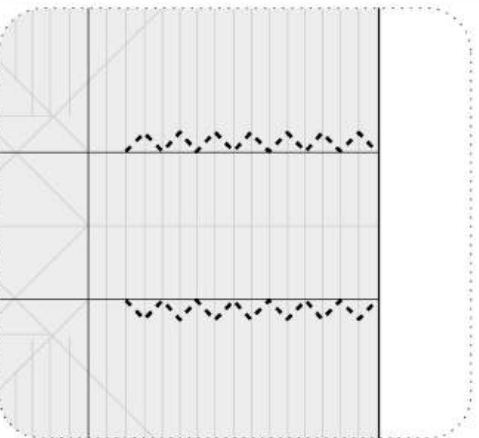

23 piega a zig zag a 45°
zig zag fold at 45°

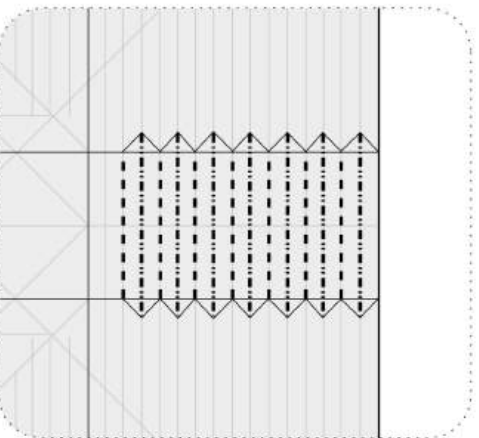

24 inverti le pieghe all'interno
change direction to the creases inside



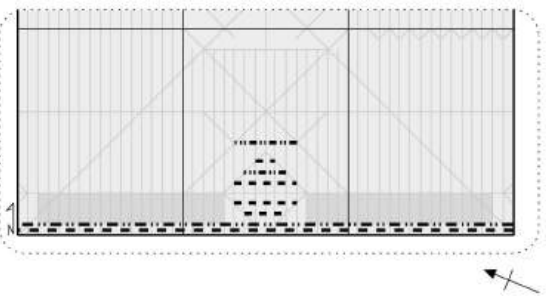

25 piega il bordo della ruota
pleat the rim of the wheel

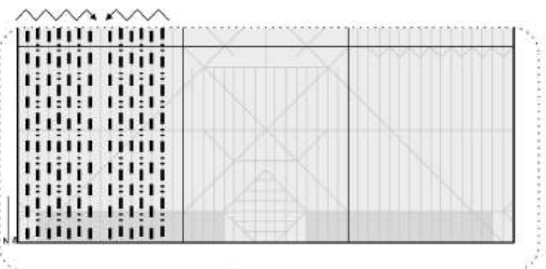

26 piega a zig zag
pleat in accordion

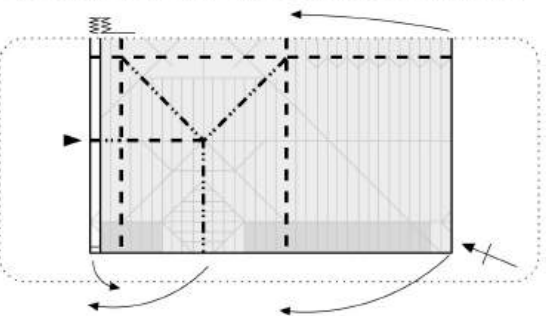

27 il modello diventa 3D
the model becomes 3D

3D

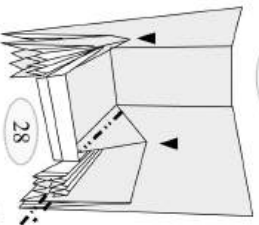

28

stesso crease pattern di 14b
same crease pattern as step 14b

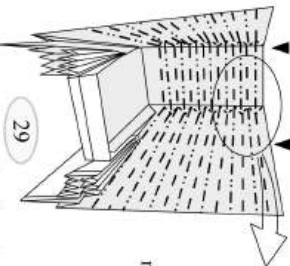

29

usa solo pieghe esistenti
use only existing creases

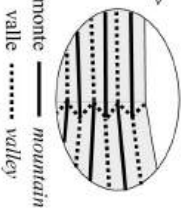

monte — mountain
valle valley

30

doppio orecchio di coniglio
double rabbit ear

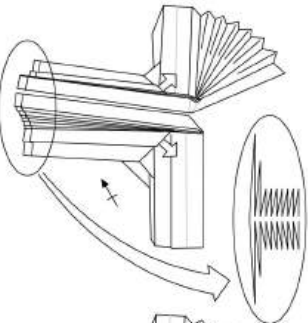

31 porta avanti uno strato
bring a layer to front

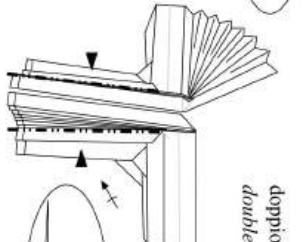

32 sink chiuso
closed sink

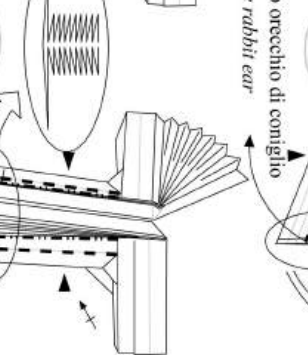

33 doppio sink chiuso
double closed sink



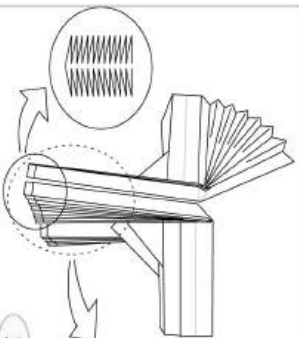

34 le ruote
the wheels

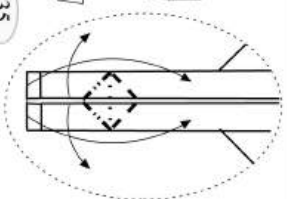

35 alza solo il primo strato
lift only the first layer

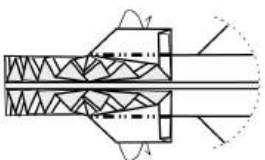

36 blocca dietro
lock behind

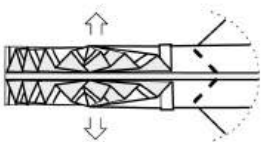

37 apri al centro
open in the middle

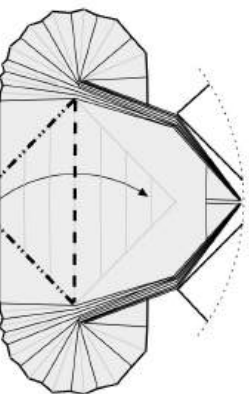

38 separa le ruote
separate the wheels

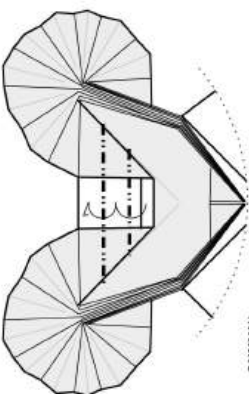

39 blocca con pieghe a monte
lock with mountain folds

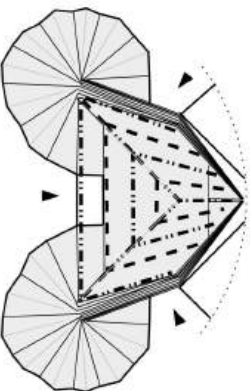

40 pieghe a fisarmonica
pleat in accordion

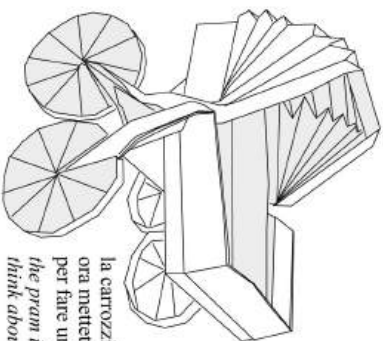

42 la carrozzina è finita...
ora mettetevi sotto
per fare un bimbo!
the pram is done... now
think about having a baby!

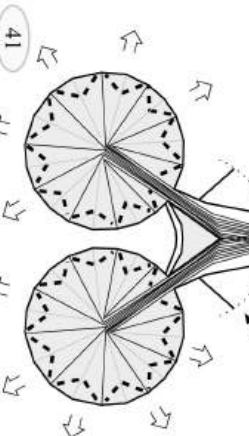

41

modella le ruote ed estrai carta da dietro per dare spessore
model the wheels and get paper from behind to obtain thickness

dedicato a Stefania



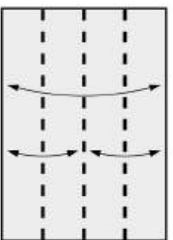

1 A4, struttura base
A4, basic structure

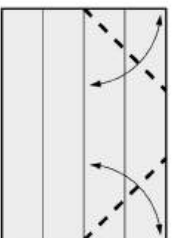

2

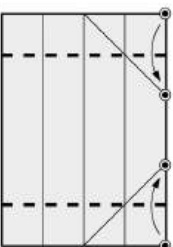

3

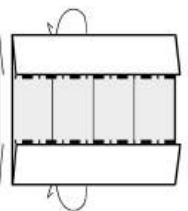

4

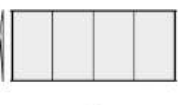

5

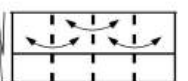

6

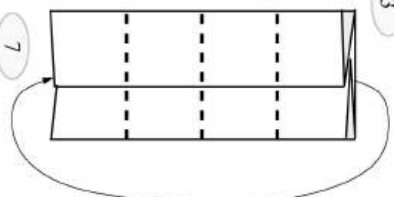

7

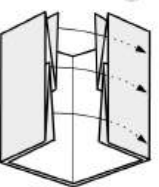

3D

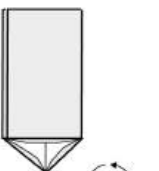

9



10

8 incastra ogni strato!
every layer must fit in!

struttura base (6 tasche,
3 sopra e 3 sotto)
basic structure (6 pockets,
3 on the top and 3 on the bottom)

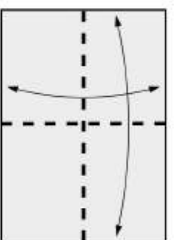

1 A4, 8 connettori A
A4, 8 joint modules A

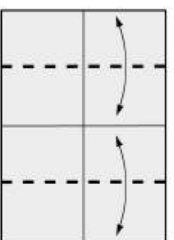

2

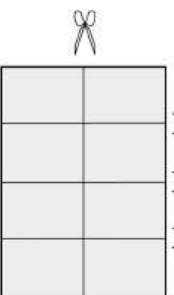

3 8 moduli A
8 A-modules

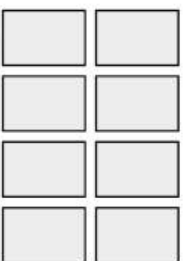

4

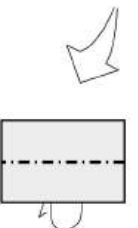

5 A7
A7



6 connettore A
joint module A



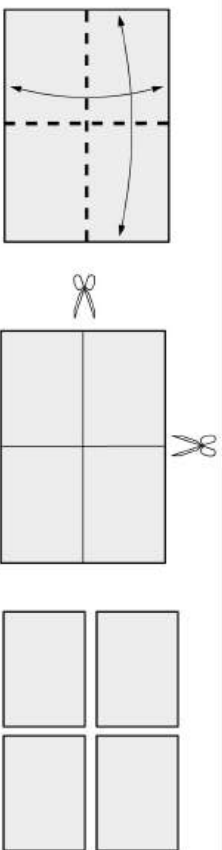

1 A4, 4 ponti B
A4, 4 bridge modules B

2 4 moduli B
4 B-modules

3



4 A6
A6

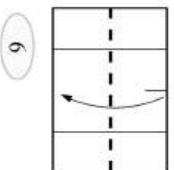
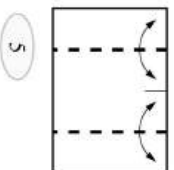
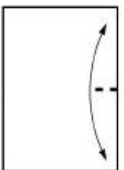

5

6

7



8 piega a 90°
fold at 90°

3 D



9

10 ponte B
bridge module B

incastri joints



2

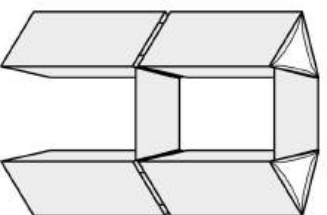
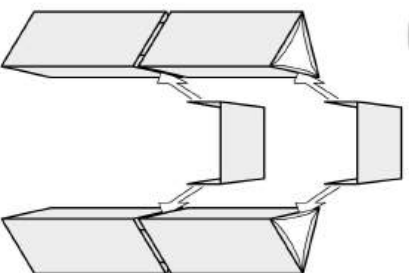

3 incastro orizzontale con 2 ponti B
horizontal joint with 2 bridge modules B

4

1 incastro verticale
con 3 connettori A
vertical joint with
3 joint modules A

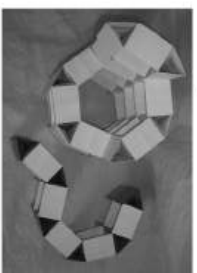
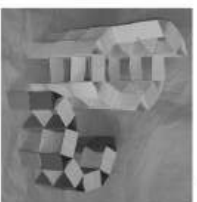

alcuni esempi di strutture costruibili con qualche decina di moduli
some examples of possible structures using some tens of modules



HLT – crease pattern progressivo

RG, 2011

HLT – progressive crease pattern

difficoltà 1 2 3 4 5

HLT significa "Human Language Technologies", l'unità di ricerca in cui lavoro
HLT means "Human Language Technologies", the research unit where I work

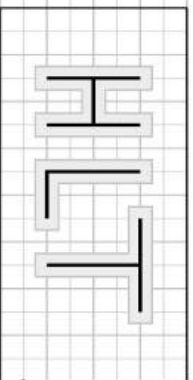

- 1 rettangolo 1x2; griglia 8x16; obiettivo
rectangle 1x2; grid 8x16; target

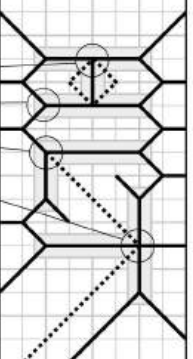

2

un teorema di Jun Maekawa dice che la differenza tra pieghe a monte e pieghe a valle deve essere 2 o -2, in ogni incrocio, per poter chiudere il CP
a theorem by Jun Maekawa says that the difference between mountain and valley folds must be 2 or -2, in every cross point, to be able to close the CP

monte ——— mountain
valle valley

4-2 = 2 : OK
3-1 = 2 : OK
3-0 = 3 : KO
3-2 = 1 : KO

KO = manca qualche piega
KO = some crease is missing

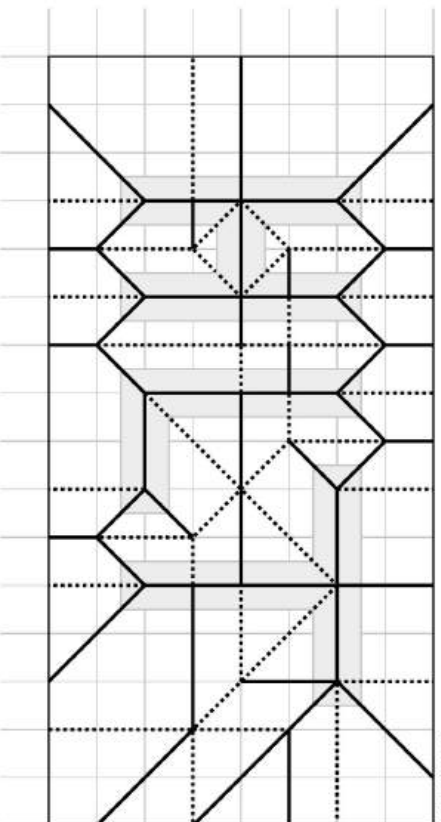

- 3 complete crease pattern: collassa ed esegui un solo taglio
complete crease pattern: collapse and make just one cut



- 4 chiusura in corso
in progress



- 5 pronto per il taglio
ready for the cut

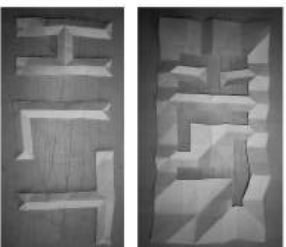

CDO – crease pattern progressivo
CDO – progressive crease pattern

RG, 2012
 difficoltà 1 2 3 4 5

monte — mountain
 valle valley

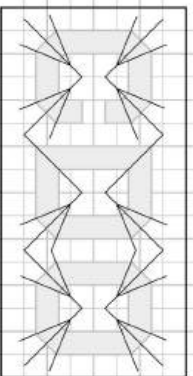

1 rettangolo 1x2; griglia 8x16; obiettivo
 rectangle 1x2; grid 8x16; target

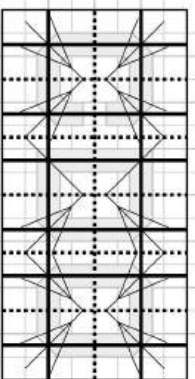

2

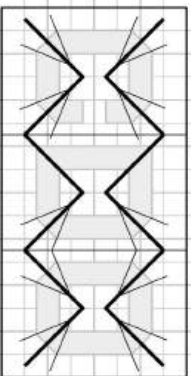

3

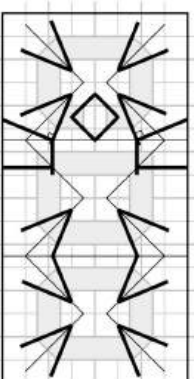

4

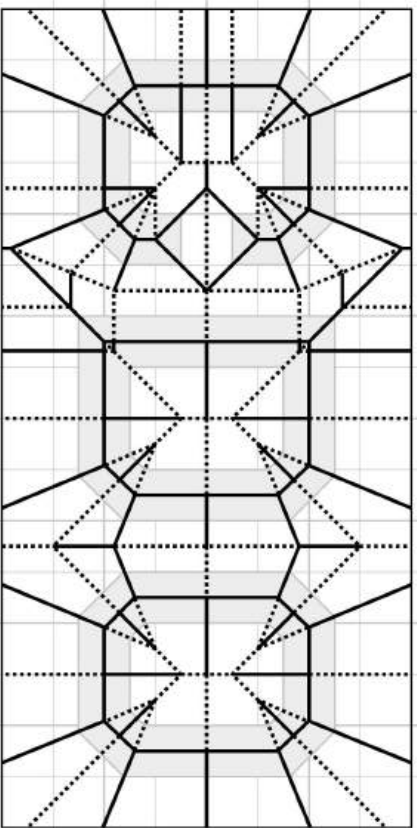

5 complete crease pattern: collassa ed esegui un solo taglio
 complete crease pattern: collapse and make just one cut



6 chiusura in corso
 in progress



7 pronto per il taglio
 ready for the cut

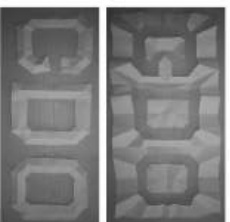

Legionario romano
Roman Legionnaire

Elmo Helmet

RG, 8 febbraio 2008
difficoltà **1 2 3 4 5**

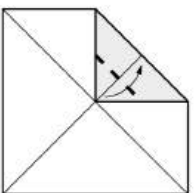
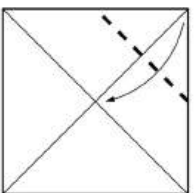
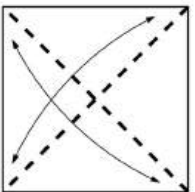

1 usa cartoncino bagnato
good for wet folding

2

3

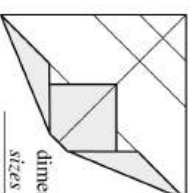
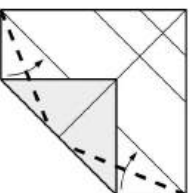
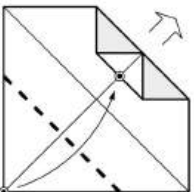
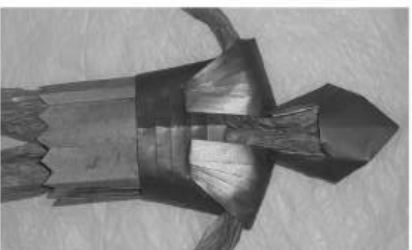

4

5

6

dimensioni sizes	indossabile wearable	pupazzo puppet
Elmo (cm) <i>Helmet (inches)</i>	65 x 65 26 x 26	12 x 12 5 x 5
Armatura (cm) <i>Armor (inches)</i>	70 x 280 27.5 x 110	12.5 x 50 5 x 20
Gonnellino (cm) <i>Skirt (inches)</i>	56 x 280 22 x 110	10 x 50 4 x 20

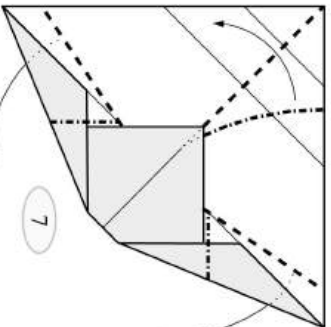

7

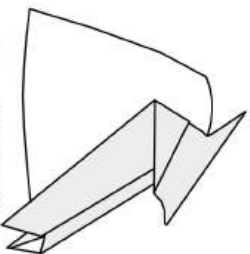

10 vista laterale
side view

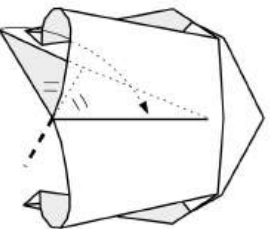

8 vista da dietro: blocca
con una piega a valle
*back view: lock
with a valley fold*

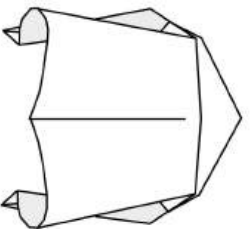

9

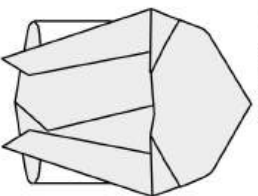

11 vista frontale
front view

3D

Armatura da legionario
Legionary armor

RG, giugno 2012
difficoltà 1 2 3 4 5

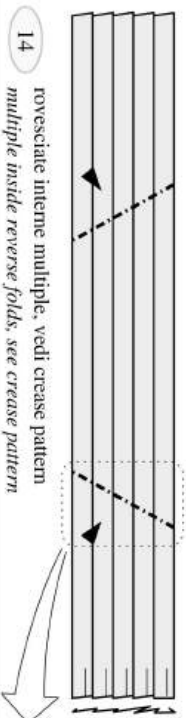
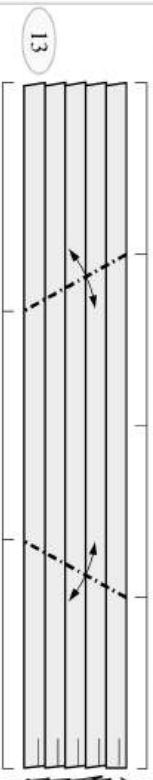
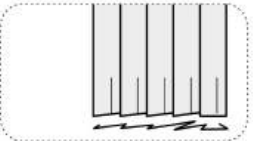
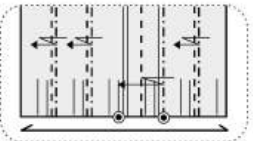
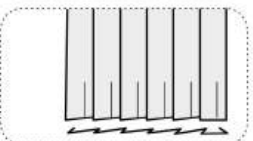
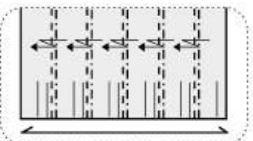
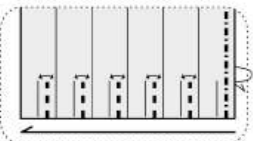
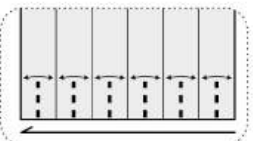
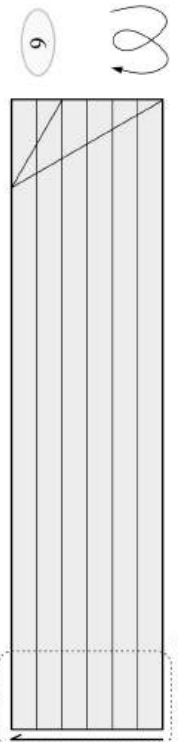
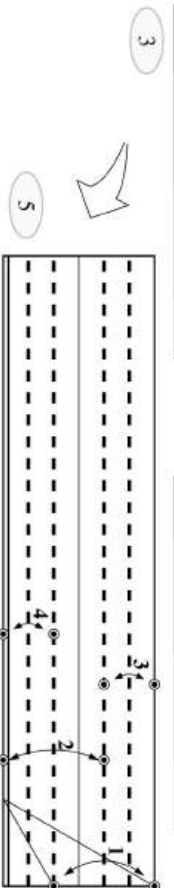
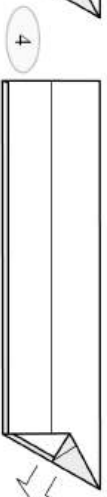
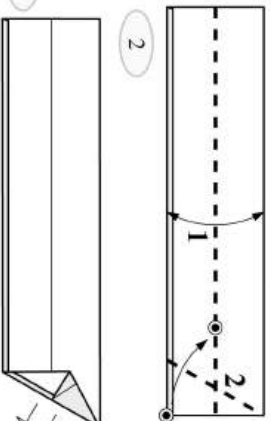
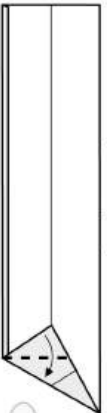
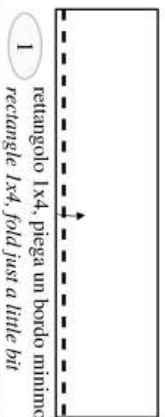

rovesciate interne multiple, vedi crease pattern
multiple inside reverse folds, see crease pattern

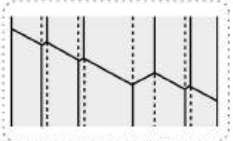

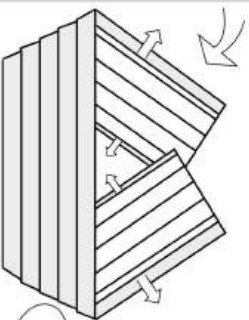

- 15 rovescia i bordi
reverse the edges

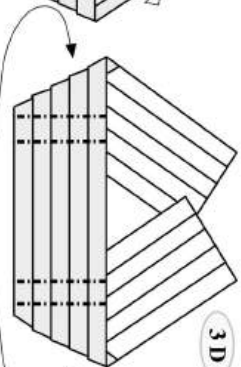

- 16 arrotonda
make it round

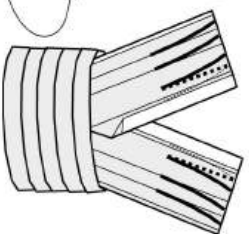

- 17 pieghe curve
curved crased

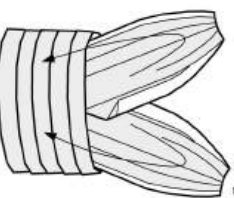

- 18 abbassa le spalline
lower the flaps

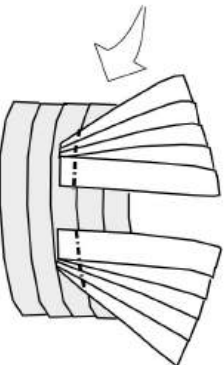

- 19 metti le alette nella tasca
put the flaps into the pocket

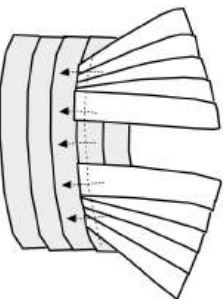

- 20 blocca da dentro
lock from inside

Gonnellino Skirt



- 1 rettangolo 1x5,
pieplega in 64esimi
*rectangle 1x5,
precrease in 64ths*

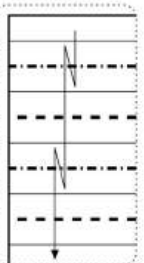

2

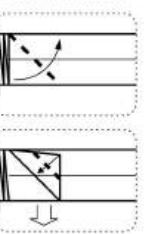

3

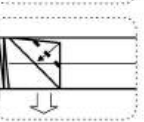

4

ripeti ovunque
repeat

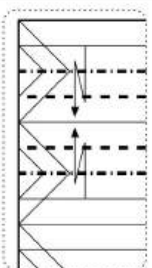

5

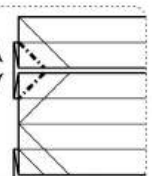

6

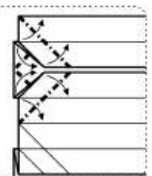

7

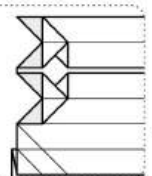

8

ripeti ovunque
repeat everywhere

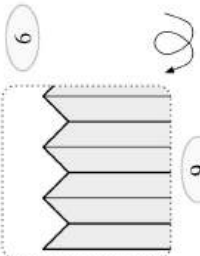

9



10

rapri, inserisci i primi 8 segmenti,
richiudi, blocca con piega a monte
*reopen, insert the first 8 segments,
close, lock with a mountain fold*

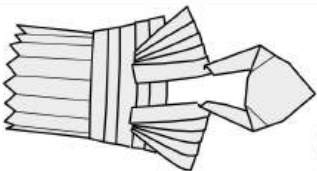

11

Albero di Natale

Christmas tree

ispirato da "scutigera" di Brian Chan
 inspired by "scutigera" by Brian Chan

RG, dicembre 2010

difficoltà 1 2 3 4 5

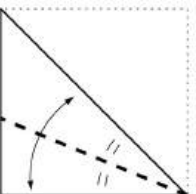

1 esercitati con mezzo quadrato
 make a try with half a square

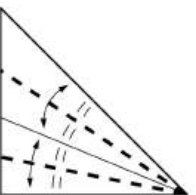

2 bisettrici ovunque
 bisect everywhere

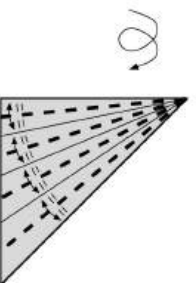

3

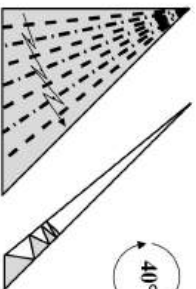

4 piega a zig-zag
 fold in accordion



5

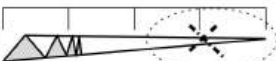

6 circa un quarto,
 non critico
 about one fourth,
 not critical

7

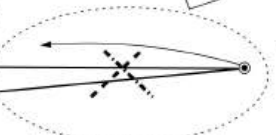

8

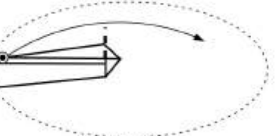

9

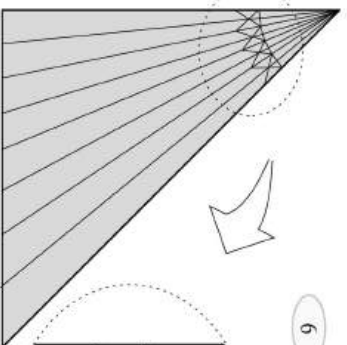
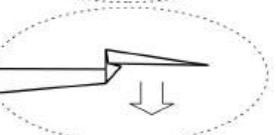

10

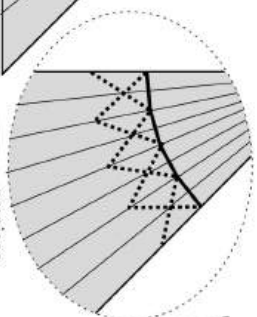

11 prepiega
 precrease

monte — mountain
 valle valley

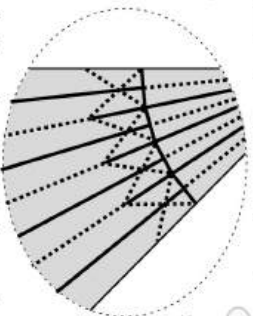

12 devi invertire tutte le pieghe sotto le X
 you must invert every crease under the X

13 collassa: è una serie di basi triangolari
 collapse: it is a sequence of triangular bases

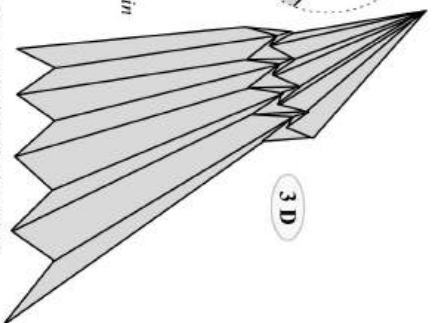

3 D



monte ——— mountain
 valle valley

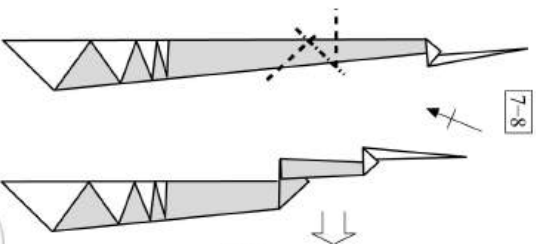

7-8

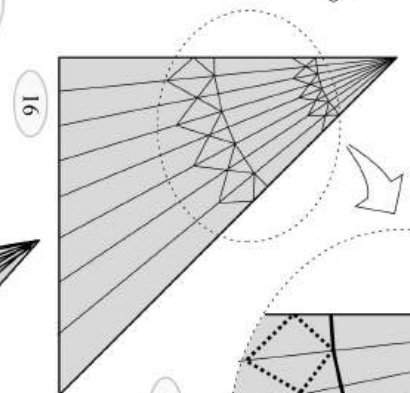

16

17
 prepiegata
 precrease

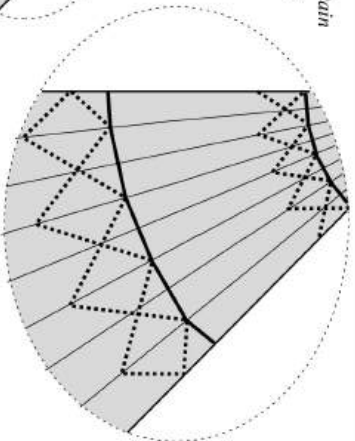

14
 circa a metà,
 non critico
 about half way,
 not critical

15

ogni spicchio ha un angolo di quasi 6°;
 se avesses un angolo maggiore, le basi
 triangolari uscerebbero troppa carta
 every slice has an angle of about 6°;
 if the angles were bigger, the
 triangular bases would use too much paper

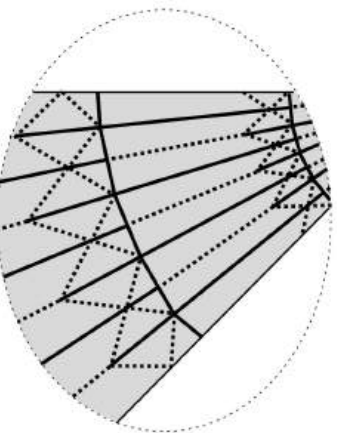

18

la parte alta rimane come prima:
 devi invertire tutte le pieghe sotto le nuove X;
 sotto c'è la stessa struttura di prima, ma spostata di un segmento
 the upper part remains as before:
 you must invert every crease under the new X;
 below there is the same structure as before, but shifted one segment

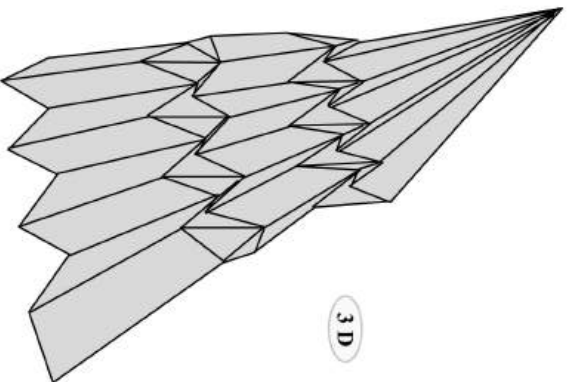

3 D

19
 crollata: è una seconda serie
 di basi triangolari
 collapse: it is a second sequence
 of triangular bases



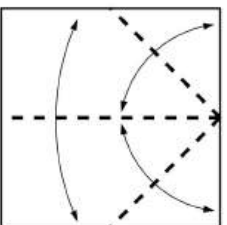

1 ora facciamo sul serio...
are you ready? really?

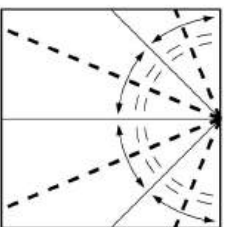

2 prepiega bisettrici
precrease bisectors

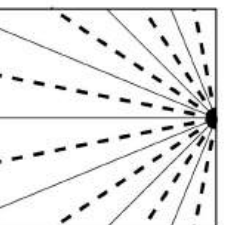

3 Icesimi a valle
16th, valley

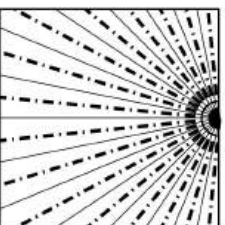

4 32esimi a monte
32th, mountain

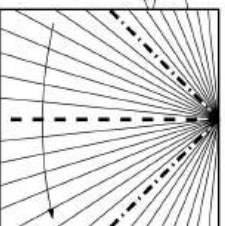

5

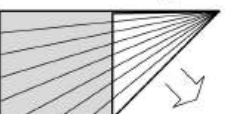

6 applica i passi 4-18 della prova
apply steps 4-18 of the trial

applicare la stessa sequenza porta a troppi strati di carta; meglio fare un pezzo alla volta; trova il tuo metodo!
to apply the same sequence leads to too many layers; better fold one piece at a time; find your way!

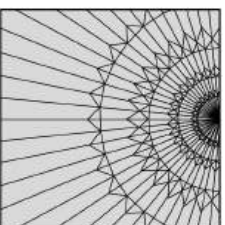

7



8 collassa
collapse

3D



9 usa i segmenti all'interno per fare un sostegno
use the internal segments to make a stand



10 sovrapposti due segmenti per chiudere il dietro
overlap 2 segments to close the back

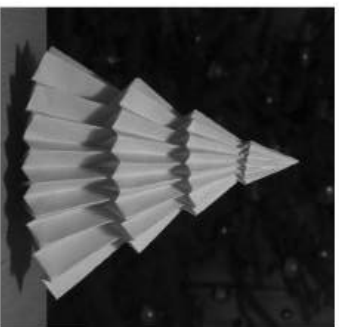

albero di Natale
Christmas tree

piega alcuni livelli: l'ultimo è un po' diverso per far puntare i segmenti verso l'interno; il modello della foto è realizzato da un rettangolo
fold some layers: the last one is slightly different, to make the segments point inside: the model in the picture is made from a rectangle



Racchetta da tennis – crease pattern

Tennis racket – crease pattern

modello basato su una tassellazione vista sul sito di Alex Bateman (credo sia sua)
model based on a tessellation seen on the webpage of Alex Bateman

RG, ottobre 2007
difficoltà 1 2 3 4 5

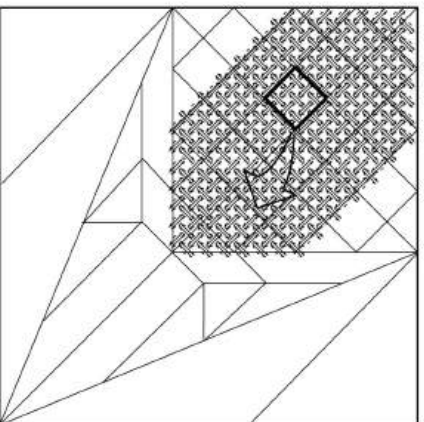
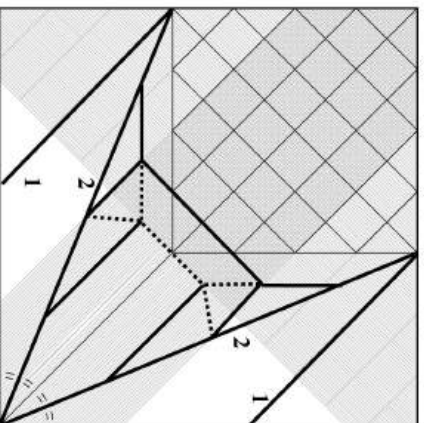

1 le pieghe di struttura vanno fatte
DOPO aver chiuso la tassellazione

structural creases must be done
AFTER the tessellation has been closed

2 zona dove piegare la tassellazione
where the tessellation must be folded

monte — mountain
valle valley

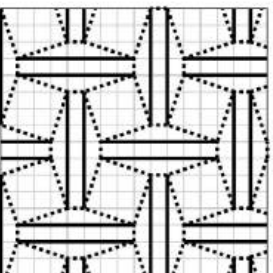

3 griglia 16x16 (uno dei quadrati)
grid 16x16 (one of the squares)

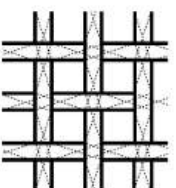

4 tassellazione chiusa (davanti)
tessellation closed (front)

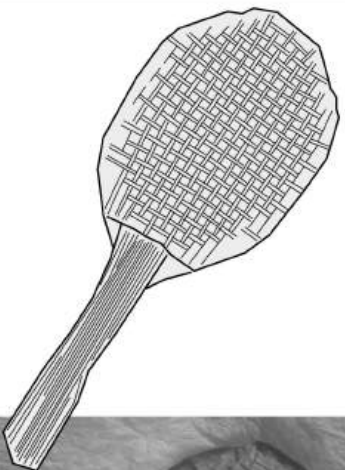

Triplano Fokker Dr. 1 – crease pattern
Fokker triplane Dr. 1 – crease pattern

RG, dicembre 2006
 difficoltà 1 2 3 4 5

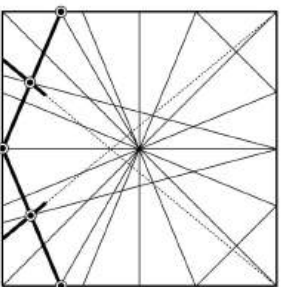
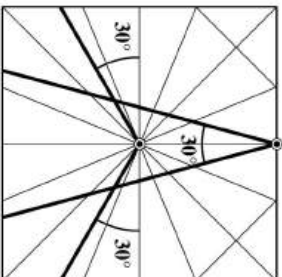
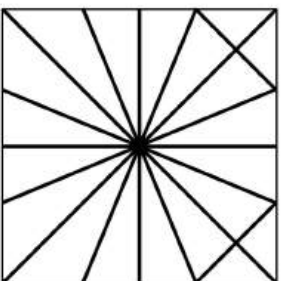

1

2

3

ala alta upper wing

monte — mountain
 valle valley

coda e alettoni vengono ottenuti modellando il centro del foglio; su tutte le ali ripetere i sink come quelli nell'area scura tail and stabilizers come from a modeling of the center of the square; on every wing make sinks like in the dark area

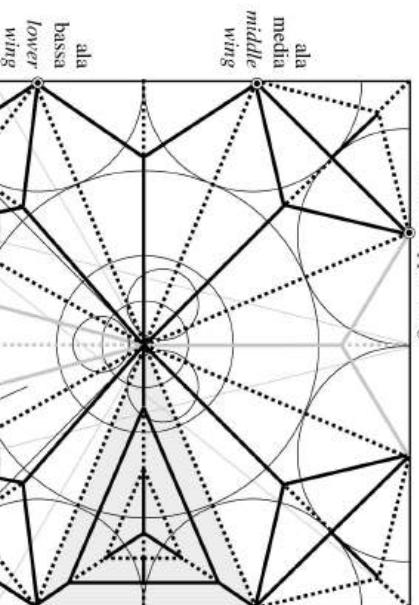

4

connessione ruote wheels connector

ruota wheel

muso plane nose

fusoliera fuselage

posizionamento delle ali placement of the wings



maledetto barone rosso!
 curse you, red baron!

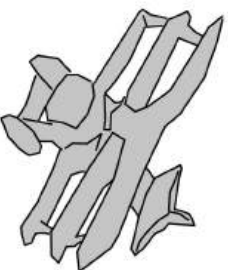

Quaderni di Quadrato Magico Pubblicati

QQM n° 1 - *Dieci bellissimi origami*
autori vari

QQM n° 2 - *La fisarmonica*
autori vari

QQM n° 3 - *Origami superstars*
autori vari

QQM n° 4 - *Origami senza frontiere*
autori vari

QQM n° 5 - *Presepe*
Luigi Leonardi

QQM n° 6 - *Origami di casa nostra*
autori vari

QQM n° 7 - *Origami tra le stelle*
Luigi Leonardi

QQM n° 8 - *Origami per gioco*
autori vari

QQM n° 9 - *Origami in fiore*
Nilva Fina Pillan

QQM n° 10 - *L'origami dalla A alla Z*
Paolo Bascetta

QQM n° 11 - *Modelli di Natale Fietta*
Natale Fietta

QQM n° 12 - *Modelli biblioteca*
autori vari

QQM n° 13 - *Modelli di Roberto Morassi*
Roberto Morassi

QQM n° 14 - *Origami contromossa*
autori vari

QQM n° 15 - *Modelli biblioteca*
autori vari

QQM n° 16 - *Cuori di carta*
autori vari

QQM n° 17 - *Le mille e una piega*
Luigi Leonardi

QQM n° 18 - *Modelli di Pasquale D'Auria*
Pasquale D'Auria

QQM n° 19 - *Le farfalle di Alfredo Giunta*
Alfredo Giunta

QQM n° 20 - *Modelli di Franco Pavarin*
Franco Pavarin

QQM n° 21 - *Modelli di Katia Violi*
Katia Violi

QQM n° 22 - *Calendariorigami di Angela Crosta*
Angela Crosta

QQM n° 23 - *Le mille e una piega n°2*
Luigi Leonardi

QQM n° 24 - *L'origami per David*
David Derudas

QQM n° 25 - *La carta viva, viva la carta*
Maria Grazia Zordan

QQM n° 26 - *Scacchi*
L. Leonardi, R. Leonardi
P. Macchi, L. Vitagliano

QQM n° 27 - *Origiochi*
Angela Crosta

QQM n° 28 - *Origami utili*
autori vari

QQM n° 29 - *Voglia di mare*
Pasquale D'Auria

QQM n° 30 - *Voglia di cielo*
Pasquale D'Auria

QQM n° 31 - *Variazioni sul modulo*
Pietro Macchi

QQM n° 32 - *Storie... fra le pieghe*
F. Decio, A. Graniero,
L. Petino, M.G. Zordan

QQM n° 33 - *Origami semplici*
autori vari

QQM n° 34 - *Origami in ordine sparso*
Daniela Carboni

QQM n° 35 - *Un fiore per Nilva*
autori vari

QQM n° 36 - *Di piega in piega*
Francesco Decio

QQM n° 37 - *Voglia di scatole*
Pasquale D'auria

QQM n° 38 - *Dodecaedri e... dintorni*
Silvana Betti Mamino

QQM n° 39 - *Origami dal Vesuvio*
Andrea Russo

QQM n° 40 - *Pieghe nel tempo*
Nicola Bandoni

QQM n° 41 - *Da stelle a ninfee*
Mauro Pucci

QQM n° 42 - *I fiori di Nilva*
a cura di F. Decio e P. Macchi

QQM n° 43 - *Vietato tagliare*
Francesco Miglionico

QQM n° 44 - *Voglia di griglie*
Pasquale D'Auria

QQM n° 45 - *Origami nel cassetto - Baby Zoo*
Luciano Petino

QQM n° 46 - *Origami semplici... ma non facili*
Federico Scalambra

QQM n° 47 - *Modulandia*
Enrica Dray

QQM n° 48 - *Scatole Modulari*
Franco Pavarin

QQM n° 49 - *Origami a 360° ... e oltre*
Roberto Gretter

QQM n° 50 - *Gioca, Studia, Piega*
Francesco Decio



CENTRO DIFFUSIONE ORIGAMI

Casella postale 28
27011 Belgioioso (PV)
e-mail: info@origami-cdo.it
web: www.origami-cdo.it